



Omaha Regional Stormwater Design Manual

# Design Of Culverts

## Chapter 4

**Revised June 2014**

City of Omaha Environmental Quality Control Division  
[www.omahastormwater.org](http://www.omahastormwater.org)

# Table of Contents

<b>4.1 Overview</b>	<b>4-1</b>
4.1.1 Introduction	4-1
4.1.2 Definition	4-1
4.1.3 Purpose	4-1
4.1.4 Considerations	4-1
4.1.5 Bridge or Culvert Selection	4-1
<b>4.2 Symbols and Definitions</b>	<b>4-3</b>
<b>4.3 Concept Definitions</b>	<b>4-4</b>
<b>4.4 Culvert Design Steps</b>	<b>4-5</b>
<b>4.5 Engineering Design Criteria</b>	<b>4-7</b>
4.5.1 Criteria	4-7
4.5.2 Flood Frequency	4-8
4.5.3 Velocity Limitations	4-8
4.5.4 Buoyancy Protection	4-8
4.5.5 Length and Slope	4-8
4.5.6 Debris Control	4-9
4.5.7 Headwater Limitations	4-9
4.5.8 Tailwater Considerations	4-10
4.5.9 Freeboard	4-10
4.5.10 Culvert Inlets	4-10
4.5.11 Inlets with Headwalls	4-10
4.5.12 Wingwalls and Aprons	4-10
4.5.13 Improved Inlets	4-13
4.5.14 Manning's n Values	4-13
4.5.15 Culvert Skews	4-13
4.5.16 Minimum Culvert Size	4-13
4.5.17 Outlet Protection	4-13
4.5.18 Permitting Considerations	4-13
4.5.19 Safety Considerations	4-13
4.5.20 Loading Requirements	4-13
<b>4.6 Culvert Flow Controls and Equations</b>	<b>4-14</b>
4.6.1 Introduction	4-14
4.6.2 Inlet and Outlet Control	4-14
4.6.3 Equations	4-14
4.6.3.1 Mild Slope	4-14
4.6.3.2 Steep Slope	4-16
4.6.3.3 Slug Flow	4-16
<b>4.7 Design Procedures</b>	<b>4-17</b>
4.7.1 Procedures	4-17
4.7.2 Tailwater Elevations	4-17
4.7.3 Culvert Design Nomographs	4-17

4.7.4	Steps in the Design Procedure .....	4-18
4.7.5	Performance Curves .....	4-21
4.7.6	Roadway Overtopping .....	4-21
4.7.7	Storage Routing .....	4-22
<b>4.8</b>	<b>Culvert Design Example Using Nomographs .....</b>	<b>4-23</b>
<b>4.9</b>	<b>Design of Improved Inlets .....</b>	<b>4-27</b>
4.9.1	Introduction .....	4-27
4.9.2	Outlet Control .....	4-27
4.9.3	Inlet Control .....	4-27
4.9.4	Common Entrances .....	4-27
4.9.5	Capacity Determinations .....	4-27
4.9.6	Improved Inlets .....	4-27
4.9.6.1	Bevel-Edged Inlet .....	4-27
4.9.6.2	Side-Tapered Inlet .....	4-28
4.9.6.3	Slope-Tapered Inlet .....	4-29
4.9.6.4	Improved Inlet Performance .....	4-29
<b>4.10</b>	<b>Design Procedures for Beveled-Edged Inlets .....</b>	<b>4-30</b>
4.10.1	Introduction .....	4-30
4.10.2	Design Figures .....	4-30
4.10.3	Design Procedure .....	4-30
4.10.4	Design Figure Limits .....	4-30
4.10.5	Area Ratios .....	4-31
4.10.6	Multibarrel Installations .....	4-31
4.10.7	Skewed Inlets .....	4-31
<b>4.11</b>	<b>HYDRAIN Culvert Computer Program .....</b>	<b>4-32</b>
4.11.1	Introduction .....	4-32
4.11.2	User-Friendly Features .....	4-32
4.11.3	Examples .....	4-32
<b>4.12</b>	<b>Construction and Maintenance Considerations .....</b>	<b>4-33</b>

## Appendices

<b>Appendix 4-A</b>	.....Culvert Design Nomographics (For Culvert And Inlet Control)
<b>Appendix 4-B</b>	.....Critical Depth Charts
<b>Appendix 4-C</b>	.....Inlet Control Design Graphs For Improved Inlet Culverts
<b>Appendix 4-D</b>	.....HY8 Culvert Analysis — Microcomputer Program
<b>Appendix 4-E</b>	.....References

## List of Tables

4-1	Symbols and Definitions .....	4-3
4-2	Inlet Coefficients .....	4-11
4-3	Manning's n Values .....	4-12
4-4	Comparison of Inlet Performance .....	4-29

## List of Figures

4-1	Typical Headwall and Wingwall Configurations .....	4-12
4-2	Headwater Depth for Concrete Pipe Culverts with Inlet Control .....	4-19
4-3	Head for Concrete Pipe Culverts Flowing Full .....	4-20
4-4	Discharge Coefficients for Roadway Overtopping .....	4-22
4-5	Culvert Calculation Form .....	4-26
4-6	Beveled Edged Inlet .....	4-28

(This page was intentionally left blank)

# Chapter 4 Design Of Culverts

## 4.1 Overview

### 4.1.1 Introduction

The design of a culvert is influenced by cost, hydraulic efficiency, purpose, and the topography at the proposed culvert site. Thus physical data must be integrated with engineering and economic considerations. The information contained in this chapter should allow design engineers to take into account the factors that influence proper design and selection of culverts.

### 4.1.2 Definitions

Culverts are enclosed conduit structures used to convey water through embankments such as streets and driveways. Culverts are usually covered with embankment and composed of structural material around the entire perimeter, although some are supported on spread footings with the streambed serving as the bottom of the culvert. Culverts that are used to convey runoff from one side of a roadway to another are sometimes referred to as cross-drains.

### 4.1.3 Purpose

The primary purpose of culverts is to convey surface water across, or from roadways. In addition to the hydraulic function, a culvert must also support the embankment material and overlying loads such as traffic. They must be designed to protect the traveling public and adjacent property from flood hazards to the extent practicable and in a reasonable and prudent manner.

### 4.1.4 Considerations

Primary considerations for the final selection of any drainage structure are that its design be based upon appropriate hydraulic principles, economy, and minimized effects on adjacent property by the resultant headwater depth and outlet velocity. In addition to sound hydraulic design, sound structural design, site design, and construction practices are necessary for a culvert to function properly. For economy and hydraulic efficiency, culverts should be designed to operate with the inlet submerged during flood flows, if conditions permit. The allowable headwater elevation is that elevation above which unacceptable damage may be caused to adjacent property and/or the roadway. It is this allowable headwater depth that is the primary basis for sizing a culvert.

For safety, access and egress routes to developed areas shall be checked to verify they will provide safely passable access for emergency vehicles and local residents during the 100-year and smaller flood events.

### 4.1.5 Bridge or Culvert Selection

At many sites, either a bridge or a culvert will fulfill the structural and hydraulic requirements. The structural choice should be based on:

- risk of property damage,
- construction and maintenance costs,
- traffic safety,
- environmental considerations,
- risk of failure, and
- aesthetic considerations.

## 4.2 Symbols And Definitions

To provide consistency within this chapter, as well as throughout this manual, the following symbols will be used. These symbols were selected because of their wide use in many culvert design publications.

**Table 4-1 Symbols, Definitions and Units**

Symbol	Definition	Units
A	Area of cross section of flow	sq. ft.
B	Barrel width	ft.
$C_d$	Overtopping discharge coefficient	-
D	Culvert diameter or barrel depth	in. or ft.
d	Depth of flow	ft.
$d_c$	Critical depth of flow	ft.
$d_u$	Uniform depth of flow	ft.
g	Acceleration of gravity	ft./s.
H	Total energy loss	ft.
$H_e$	Entrance head loss	ft.
$H_f$	Friction head loss	ft.
$h_o$	Height of hydraulic grade line above outlet invert	ft.
HW	Headwater depth above invert of culvert entrance	ft.
$K_e$	Inlet loss coefficient	—
L	Length of culvert	ft.
P	Empirical approximation of equivalent hydraulic grade line	ft.
Q	Rate of discharge	cfs
S	Slope of culvert	ft./f
TW	Tailwater depth above invert of culvert outlet	ft.
V	Mean velocity of flow	ft./s.
$V_c$	Critical velocity	ft./s.

## 4.3 Concept Definitions

**Critical Depth** — Critical depth can best be illustrated as the depth at which water flows over a weir, this depth being attained automatically where no other backwater forces are involved. For a given discharge and cross-section geometry there is only one critical depth. [Appendix B](#) at the end of this chapter gives a series of critical depth charts for the different culvert shapes.

**Uniform Flow** — Uniform flow is flow in a prismatic channel of constant cross section having a constant discharge, velocity and depth of flow throughout the reach. This type of flow will exist in a culvert operating on a steep slope provided the culvert is sufficiently long.

**Free Outlets** — Free outlets are outlets whose tailwater is equal to or lower than critical depth. For culverts having free outlets, lowering of the tail water has no effect on the discharge or the backwater profile upstream of the tail water.

**Submerged Outlets** — Partially submerged outlets are outlets whose tailwater is higher than critical depth and lower than the height of the culvert. Submerged outlets are outlets having a tailwater elevation higher than the soffit of the culvert.

**Submerged Inlets** — Submerged inlets are those inlets having a headwater greater than about one and one-half times the diameter of the culvert.

**Improved Inlets** — Flared, improved, or tapered inlets indicate a special entrance condition which decreases the amount of energy needed to pass the flow through the inlet and thus increases the capacity of culverts at the inlet.

**Soffit** — Soffit refers to the inside top of the culvert. The soffit is also referred to as the crown of the culvert.

**Invert** — Invert refers to the flow line of the culvert (inside bottom).

**Steep and Mild Slope** — A steep slope culvert operation is where the computed critical depth is greater than the computed uniform depth. A mild slope culvert operation is where critical depth is less than uniform depth.

## 4.4 Culvert Design Steps

Use of manual nomographs and use of FHWA HY8 for design by computer are the two culvert design procedures described later in this chapter. In general, the following steps are the recommended in the design of a culvert in order to ensure that all design aspects are taken into account.

**Step 1 Determine And Analyze Site Characteristics** — Site characteristics include the generalized shape of the roadway embankment; bottom elevations and cross-sections along the streambed for several hundred feet upstream and downstream of the proposed culvert location; the approximate length of the culvert; and the allowable headwater elevation. In determining the allowable headwater elevation, roadway elevations and the elevation of upstream property should be considered. The consequences of exceeding the allowable headwater elevation should be evaluated and kept in mind throughout the design process.

Culvert design is actually a trial-and-error procedure because the length of the barrel cannot be accurately determined until the size is known, and the size cannot be precisely determined until the length is known. In most cases, however, a reasonable estimate of length will be accurate enough to determine the culvert size.

**Step 2 Perform Hydrologic Analysis** — Delineate the drainage area above the culvert site. Develop flow estimates for the design frequencies. The probable accuracy of the estimate should be kept in mind as the design proceeds.

**Step 3 Perform Outlet Control Calculations And Select Culvert** — Generally, these calculations should be performed before inlet control calculations in order to select the smallest feasible barrel which can be used without the required headwater elevation in outlet control exceeding the allowable headwater elevation. The full flow outlet control performance curve for a given culvert (size, inlet edge, shape, material) defines its maximum performance. Therefore, the inlet improvements beyond the beveled edge or changes in inlet invert elevation will not reduce the required outlet control headwater elevation. This makes the outlet control performance curve an ideal limit for improved inlet design. The results of these calculations should be the outlet control performance curve. In addition to considering the allowable headwater elevation, the velocity of flow at the exit of the culvert should be checked to determine if downstream erosion problems will be created.

**Step 4 Perform Inlet Control Calculations For Conventional And Beveled Edge Culvert Inlets** — Perform the inlet control calculations to develop the inlet control performance curve to determine if the culvert design selected will be on inlet or outlet control for the design, and check flood frequencies. A drop may be incorporated upstream of the culvert to increase the flow through the culvert.

**Step 5 Perform Throat Control Calculations For Side- And Slope-Tapered Inlets** — The same concepts are involved here as with conventional or beveled edge culvert design.

**Step 6 Analyze The Effect of a Drop On Inlet Control Section Performance** — The purpose of this step is to determine if having a drop before the inlet of the culvert would increase the capacity of the culvert and if a drop can be justified from a cost perspective and site characteristics.

**Step 7 Design Side- And/Or Slope-Tapered Inlet** — Side- and slope-tapered inlets can be used to significantly increase the capacity of many culvert designs. Develop performance curves based on side- and/or slope-tapered inlets and determine from a cost perspective and site characteristics if such a design would be justified.

**Step 8** At each step in the culvert selection process, the flow velocity at the exit of the culvert needs to be checked to evaluate resulting downstream erosion.

**Step 9 Complete File Documentation** — Complete a documentation file for the final design selected.

## 4.5 Engineering Design Criteria

### 4.5.1 Criteria

The design of a culvert should take into account many different engineering and technical aspects at the culvert site and adjacent areas. The following design criteria should be considered for all culvert designs as applicable.

- |                      |   |
|----------------------|---|
| Engineering Aspects: | <ul style="list-style-type: none"> <li>• Flood frequency</li> <li>• Velocity limitation</li> <li>• Buoyancy protection</li> </ul>   |
| Site Criteria:       | <ul style="list-style-type: none"> <li>• Length and slope</li> <li>• Debris control</li> </ul>  |
| Design Limitations:  | <ul style="list-style-type: none"> <li>• Headwater</li> <li>• Tailwater conditions</li> <li>• Storage</li> </ul>  |
| Design Options:      | <ul style="list-style-type: none"> <li>• Culvert inlets</li> <li>• Inlets with headwalls</li> <li>• Wing walls and aprons</li> <li>• Improved inlets</li> <li>• Material selection</li> <li>• Culvert skews</li> <li>• Culvert sizes</li> </ul> |
| Related Designs:     | <ul style="list-style-type: none"> <li>• Weep holes</li> <li>• Outlet protection</li> <li>• Erosion and sediment control</li> <li>• Environmental considerations</li> <li>• Safety considerations</li> <li>• Loading requirements</li> </ul>    |

Some culvert designs are relatively simple, involving a straight-forward determination of culvert size and length. Other designs are more complex where structural, hydraulic, environmental, or other considerations must be evaluated and provided for in the final design. The design engineer must incorporate personal experience and judgment to determine which criteria must be evaluated and how to design the final culvert installation.

Following is a discussion of each of the above criteria as it relates to culvert siting and design.

## 4.5.2 Flood Frequency

Culverts shall be designed to convey (at a minimum) the 50-year runoff event with two (2) ft. of freeboard to the roadway top of curb (or roadway edge if no curb). The flow rate shall be based on upstream fully-built out land-use conditions as required by the policies of the Watershed Master Plan. Where roadside ditches convey the minor storm drainage in lieu of storm sewers, appurtenant culverts shall be designed to convey the 10-year storm event, but in no case shall be less than the minimum sizes specified in [Section 4.5.16](#) of this chapter.

Engineering judgment, or an economic analysis may indicate necessity for design to pass floods greater than those noted above at locations where potential flood hazard to adjacent property or human life is significant.

Also, in compliance with the National Flood Insurance Program, it is necessary to consider the 100-year frequency flood at locations identified as being special flood hazard areas. This does not necessitate that the culvert be sized to pass the 100-year flood, provided the capacity of the culvert, plus flow by-passing the culvert, is sufficient to accommodate the 100-year flood without raising the associated water surface elevation more than floodplain regulations or adjacent property elevations allow for that location. In addition, storm water management facilities cannot be installed which would result in a major lowering of the associated water surface elevation without a downstream evaluation. The design engineer shall review the City floodplain and floodway regulations for more information.

## 4.5.3 Velocity Limitations

Both minimum and maximum velocities should be considered when designing a culvert. The maximum velocity should not exceed culvert manufacturer recommendations. The maximum velocity should be consistent with channel stability requirements at the culvert outlet. As outlet velocities increase, the need for channel stabilization at the culvert outlet increases. If velocities exceed permissible velocities for the various types of nonstructural outlet lining material available, energy dissipation may be required at the outlet of the culvert (see Chapter 7).

A minimum velocity of 3.0 ft./s. when the culvert is flowing partially full is recommended to ensure a self-cleaning condition during partial depth flow.

## 4.5.4 Buoyancy Protection

Headwalls, end walls, slope paving or other means of anchoring to provide buoyancy protection should be considered for all flexible culverts. The potential for buoyancy is generally increased with greater steepness of culvert slope, depth of potential headwater (debris blockage may increase), flatness of the upstream fill slope, height of the fill, large culvert skews, or mitered ends.

## 4.5.5 Length and Slope

Since the capacity of culverts on outlet control will be affected by the length of the culvert, their length should be kept to a minimum and existing facilities shall not be extended without determining the decrease in capacity that will occur. In addition, the culvert length and slope should be chosen to approximate existing topography. To the degree practicable, the culvert invert should be aligned with the channel bottom and the skew angle of the stream, and the culvert entrance should fit with the geometry of the roadway embankment.

## 4.5.6 Debris Control

The need for bar grates should be considered for each culvert site, but in general, bar grates shall not be used on end sections for culvert outlets unless approved by the Director of Public Works.

## 4.5.7 Headwater Limitations

The allowable headwater elevation is determined from an evaluation of land use upstream of the culvert and the proposed roadway elevation. Headwater is the depth of water above the culvert invert measured at the entrance end of the culvert. Often existing culverts can be reworked with single or double headwalls, rather than replaced, to decrease the headwater depth to the required design level.

The following criteria related to headwater should be considered:

- 1) The allowable headwater for design frequency conditions should allow for the following upstream controls:
  - Minimum 2 ft. freeboard to top of roadway curb (or roadway edge, if no curb).
  - Avoidance of upstream property damage.
  - Elevations established to delineate floodplain zoning.
  - Low point in the road grade either adjacent to or away from the culvert location.
  - Ditch elevation of the terrain that would permit flow to divert around culvert.
- 2) The headwater shall be checked for the 100-year flood to ensure compliance with street cross-flow limitations of Chapter 3, floodplain management regulations, and to avoid flooding of building sites. For most facilities, the culvert should be sized to maintain flood-free conditions on major thoroughfares for one-lane or two-lane facilities and one lane each direction of multi-lane facilities.
- 3) The maximum acceptable outlet velocity shall be identified. Either the headwater shall be set to produce acceptable velocities or stabilization measures shall be provided where these velocities are exceeded.
- 4) Site-specific design considerations shall be addressed.
- 5) In general the constraint which gives the lowest allowable headwater elevation establishes the criteria for the hydraulic calculations.

Invert elevations will be established after determining the allowable headwater elevation, tailwater elevation, and approximate length. Scour can be minimized if the culvert has the same slope as the channel. Thus, to reduce the chance of failure due to scour, invert elevations should correspond to the natural grade where feasible. In addition, the flow conditions and velocity in the channel upstream from the culvert should be investigated to determine if scour will occur.

If there is insufficient headwater elevation to convey the required discharge, it will be necessary to either use a larger culvert, lower the inlet invert, use an irregular cross section, use an improved inlet if in inlet control, use multiple barrels or a bridge, or use a combination of these measures. If the inlet invert is lowered, special consideration must be given to scour.

### 4.5.8 Tailwater Considerations

The hydraulic conditions downstream of the culvert site must be evaluated to determine a tailwater depth for a range of discharge. At times there may be a need for calculating backwater curves to establish the tailwater conditions. If the culvert outlet is operating with a free outfall, the critical depth and equivalent hydraulic grade line should be determined.

For culverts which discharge to an open channel, the stage-discharge curve for the channel must be determined. (See Chapter 5.)

If an upstream culvert outlet is located near a downstream culvert inlet, the headwater elevation of the downstream culvert may establish the design tailwater depth for the upstream culvert.

If the culvert discharges to a lake, pond, or other major water body, the expected high water elevation of the particular water body may establish the culvert tailwater.

### 4.5.9 Freeboard

The standard design of culverts is for a 50-year flow with two (2) ft. minimum of freeboard to the roadway. If in accordance with the standards listed in Table 3-4, the 100-year flow may overtop the roadway.

### 4.5.10 Culvert Inlets

Selection of the type of inlet is an important part of culvert design, particularly with inlet control. Hydraulic efficiency and cost can be significantly affected by inlet conditions.

The inlet coefficient  $K_e$ , is a measure of the hydraulic efficiency of the inlet, with lower values indicating greater efficiency. All methods described in this chapter, directly or indirectly, use inlet coefficients. Recommended inlet coefficients are given in [Table 4-2](#).

### 4.5.11 Inlet With Headwalls

Headwalls may be used for a variety of reasons:

- increasing the efficiency of the inlet
- providing embankment stability
- providing embankment protection against erosion
- providing protection from buoyancy or
- to shorten the length of the required structure.

The primary reasons for using headwalls are for embankment protection, buoyancy control, and ease of maintenance. [Figure 4-1](#) shows typical headwall and wing wall configurations. Culvert or storm sewer headwalls constructed in or adjacent to public right-of-way shall be designed to protect pedestrians. This protection shall include a pipe railing fence on the headwall and any wing walls, unless the grading and size of the pipe precludes the need for the fence, as approved by the Director of Public Works.

### 4.5.12 Wingwalls and Aprons

Wingwalls are used where the side slopes of the channel adjacent to the entrance are unstable or where the culvert is skewed to the normal channel flow.

Table 4-2 Inlet Coefficients

Type of Structure and Design of Entrance		Coefficient $K_e$
Pipe, Concrete	Projecting from fill, socket end (groove-end)	0.2
	Projecting from fill, square cut end	0.5
	Headwall or headwall and wing walls	
	Socket end of pipe (groove-end)	0.2
	Square-edge	0.5
	Rounded [radius = $1/12(D)$ ]	0.2
	Mitered to conform to fill slope	0.7
	*End-Section conforming to fill slope	0.5
	Beveled edges, 33.7° or 45° bevels	0.2
	Side- or slope-tapered inlet	0.2
Pipe, or Pipe-Arch, Corrugated Metal	Projecting from fill (no headwall)	0.9
	Headwall or headwall and wing walls square-edge	0.5
	Mitered to fill slope, paved or unpaved slope	0.7
	*End-Section conforming to fill slope	0.5
	Beveled edges, 33.7° or 45° bevels	0.2
	Side- or slope-tapered inlet	0.2
Box, Reinforced Concrete	Headwall parallel to embankment (no wing walls)	
	Square-edged on 3 edges	0.5
	Rounded on 3 edges to radius of $[1/12(D)]$ or beveled edges on 3 sides	0.2
	Wing walls at 30° to 75° to barrel	
	Square-edged at crown	0.4
	Crown edge rounded to radius of $[1/12(D)]$ or beveled top edge	0.2
	Wing walls at 10° or 25° to barrel	
	Square-edged at crown	0.5
	Wing walls parallel (extension of sides)	
	Square-edged at crown	0.7
	Side- or slope-tapered inlet	0.2

Note: End Sections conforming to fill slope, made of either metal or concrete, are the sections commonly available from manufacturers. From limited hydraulic tests they are equivalent in operation to a headwall in both inlet and outlet control. Some end sections incorporating a closed taper in their design have a superior hydraulic performance.

Source: Federal Highway Administration "Design of Highway Culverts". Hydraulic Design Series No. 5, 1985. (FHWA HDS No. 5)

Little increase in hydraulic efficiency is realized with the use of wingwalls, regardless of the pipe material used and, therefore, the use should be justified for other reasons. Wingwalls can be used to increase hydraulic efficiency if designed as a side-tapered inlet (See [Section 4.9.6.2](#) for more information on the design of side-tapered inlets.)

If high headwater depths are to be encountered, or the approach velocity in the channel will cause scour, a channel apron with a toewall should be provided at the toe of the headwall. This apron should extend at least one pipe diameter upstream from the entrance, and the top of the apron should not protrude above the normal streambed elevation.

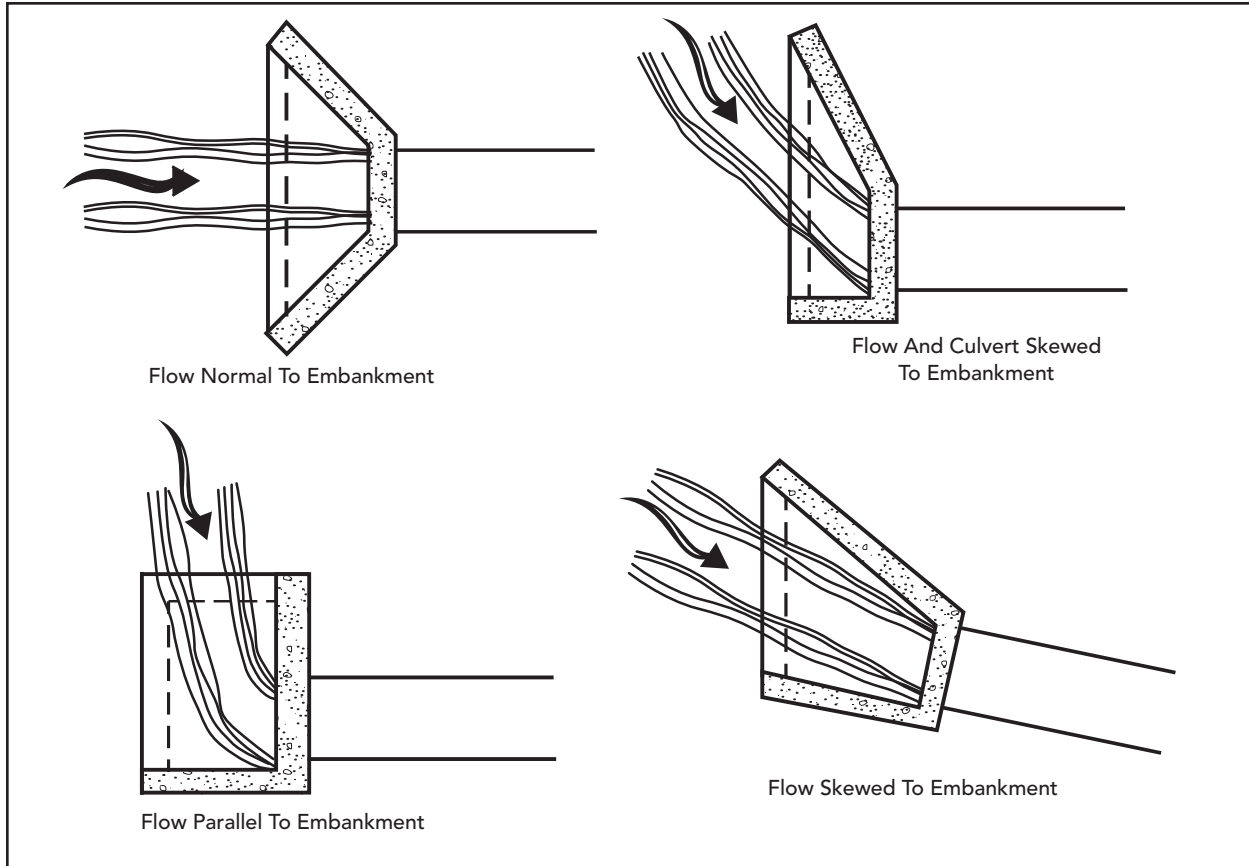

Figure 4-1 Typical Headwall and Wingwall Configurations

Source: Wright-McLaughlin Engineers

Table 4-3 Manning’s N Values

Type	Wall & Joint Description	Manning's n
Concrete Pipe	Good joints, smooth walls	0.011-0.013
	Good joints, rough walls	0.014-0.016
	Poor joints, rough walls	0.016-0.017
Concrete Box	Good joints, smooth finished walls	0.014-0.018
	Poor joints, rough, unfinished walls	0.014-0.018
Corrugated Metal Pipes And Boxes, Annular Corrugation	2 2/3 by 1/2-in. corrugations	0.027-0.022
	6 by 1-in. corrugations	0.025-0.022
	5 by 1-in. corrugations	0.026-0.025
	3 by 1-in. corrugations	0.028-0.027
	6 by 2-in. structural plate	0.035-0.033
	9 by 2 1/2-in. structural plate	0.037-0.033
Corrugated Metal Pipes 24-in. plate width, Helical Corrugations, Full Circular Flow	2 2/3 by 1/2-in. corrugated	0.024-0.020

For further information concerning Manning n values for selected conduits, consult FHWA HDS No. 5, page 163.

### 4.5.13 Improved Inlets

Where inlet conditions control the amount of flow that can pass through the culvert, improved inlets can greatly increase the hydraulic performance at the culvert. For these designs refer to [Section 4.9](#) which describes the design of improved inlets.

### 4.5.14 Manning's n Values

[Table 4-3](#) gives recommended Manning's n values for various types of culverts. Culvert construction materials must be in accordance with City of Omaha Standard Specifications.

### 4.5.15 Culvert Skews

Culvert skews shall not exceed 45 degrees as measured from a line perpendicular to the roadway centerline without approval of the Director of Public Works.

### 4.5.16 Minimum Culvert Size

The minimum culvert size shall be 18 in. for roadways and 15 in. for driveways.

### 4.5.17 Outlet Protection

See Chapter 7 for information on the design of outlet protection. In general, outlet protection will be needed at all culvert outlets to dissipate energy and control scour erosion.

### 4.5.18 Permitting Considerations

There may be federal or state permitting implications that affect the culvert design. These could include wetlands, regulatory floodplains and preparation of a stormwater pollution prevention plan for construction activity.

### 4.5.19 Safety Considerations

Traffic should be protected from culvert ends as follows.

- Small culverts should use an end section or a sloped headwall.
- Large culverts should receive one of the following treatments:
  - a. Be extended to the appropriate "clear zone" distance per AASHTO Roadside Design Guide.
  - b. Shielded with a traffic barrier if the culvert is very large, cannot be extended, or has a channel which cannot be safely traversed by a vehicle.
- Each culvert should be routinely inspected to determine if safety issues exist for traffic, structural integrity of the culvert and embankment, or hydraulic performance.

### 4.5.20 Loading Requirements

All culverts shall be designed, as a minimum, for HS20 live load, with the appropriate impact factor, and dead load. Dead load (fill) shall be based on the depth of earth cover, plus pavement, above the top of the culvert.

## 4.6 Culvert Flow Controls and Equations

### 4.6.1 Introduction

Generally, the hydraulic control in a culvert will be at the culvert outlet if the culvert is operating on a mild slope. Entrance control usually occurs if the culvert is operating on a steep slope. The design procedures contained in this chapter are for the design of culverts for a constant discharge, considering inlet and outlet control.

### 4.6.2 Inlet and Outlet Control

**Inlet Control** - For inlet control, the entrance characteristics of the culvert are such that the entrance head losses are predominant in determining the headwater of the culvert. The barrel will carry water through the culvert more efficiently than the water can enter the culvert.

**Outlet Control** - For outlet control, the head losses due to tailwater and barrel friction are predominant in controlling the headwater of the culvert. The entrance will allow the water to enter the culvert faster than the backwater effects of the tailwater and barrel friction will allow it to flow through the culvert.

Proper culvert design and analysis requires checking for both inlet and outlet control to determine which will govern particular culvert designs. For more information on inlet and outlet control see FHWA HDS No. 5.

### 4.6.3 Equations

There are many combinations of conditions which classify a particular culvert's hydraulic operation. By consideration of a succession of parameters; the engineer may arrive at the appropriate calculation procedure. The most common types of culvert operations for any barrel type are classified as follows.

#### 4.6.3.1 Mild Slope

**Critical Depth - Outlet Control** — The entrance is unsubmerged ( $HW < 1.5D$ ), the critical depth is less than uniform depth at the design discharge ( $d_c < d_u$ ) and the tailwater is less than or equal to critical depth ( $TW < d_c$ ). This condition is a common occurrence where the natural channels are on flat grades and have wide, flat floodplains. The control is critical depth at the outlet.

$$HW = d_c + V_c^2 / (2g) + H_e + H_f - SL \quad (4.1)$$

Where:

HW = headwater depth (ft.)  
 $d_c$  = critical depth (ft.)  
 $V_c$  = critical velocity  
 $g$  = 32.2 (ft./s.<sup>2</sup>)  
 $H_e$  = entrance headloss (ft.)  
 $H_f$  = friction headloss (ft.)  
 $S$  = slope of culvert (ft./ft.)  
 $L$  = length of culvert (ft.)

**Tailwater Depth - Outlet Control** — The entrance is unsubmerged ( $HW < 1.5D$ ), the critical depth is less than uniform depth at design discharge ( $d_c < d_u$ ) and TW is greater than critical depth ( $TW > d_c$ ) and TW is less than D ( $TW < D$ ). This condition is a common occurrence where the channel is deep, narrow, and well defined. The control is tailwater at the culvert outlet. The outlet velocity is the discharge divided by the area of flow in the culvert at tailwater depth.

$$HW = TW + V^2/(2g) + H_e + H_f - SL \quad (4.2)$$

Where:

- HW = headwater depth (ft.)
- TW = tailwater at the outlet (ft.)
- V = velocity based on tailwater depth (ft.)
- g = 32.2 (ft./s.<sup>2</sup>)
- H<sub>e</sub> = entrance headloss (ft.)
- H<sub>f</sub> = friction headloss (ft.)
- S = slope of culvert (ft./ft.)
- L = length of culvert (ft.)

**Tailwater Depth > Barrel Depth - Outlet Control** — This condition will exist if the critical depth is less than uniform depth at the design discharge ( $d_c < d_u$ ) and TW depth is greater than D ( $TW > D$ ), or; the critical depth is greater than the uniform depth at the design discharge ( $d_c > d_u$ ) and TW is greater than (SL + D), [ $TW > (SL + D)$ ]. The HW may or may not be greater than 1.5D, though often it is greater. If the critical depth of flow is determined to be greater than the barrel depth (only possible for rectangular culvert barrels), then this operation will govern. Outlet velocity is based on full flow at the outlet.

$$HW = H + TW - SL \quad (4.3)$$

Where:

- HW = headwater depth (ft.)
- H = total head loss of discharge through culvert (ft.)
- TW = tailwater depth (ft.)
- SL = culvert slope times length of culvert (ft.)

**Tailwater Depth < Barrel Depth - Outlet Control** — The entrance is submerged ( $HW > 1.5D$ ) and the tailwater depth is less than D ( $TW < D$ ). Normally, the engineer should arrive at this type of operation only after previous consideration of the operations depth covered when the critical depth, tailwater depth, or "slug" flow controls the flow in outlet control conditions. On occasion, it may be found that ( $HW > 1.5D$ ) for the three previously outlined conditions but ( $HW < 1.5D$ ) for Equation 4.4. If so, the higher HW should be used. Outlet velocity is based on critical depth if TW depth is less than critical depth. If TW depth is greater than critical depth, outlet velocity is based on TW depth.

$$HW = H + P - SL \quad (4.4)$$

Where:

- HW = headwater depth (ft.)
- H = total head loss of discharge through culvert (ft.)
- P = empirical approximation of equivalent hydraulic grade line (ft.)
- P =  $(d_c + D)/2$  if TW depth is less than critical depth at design discharge  
If TW is greater than critical depth, then  $P = TW$  (ft.)
- SL = culvert slope times length of culvert (ft.)

### 4.6.3.2 Steep Slope

**Tailwater Insignificant - Inlet Control** — The entrance may be submerged or unsubmerged, the critical depth is greater than uniform depth at the design discharge ( $d_c > d_u$ ), TW depth is less than SL (tailwater elevation is lower than the upstream flow line). Tailwater depth with respect to the diameter of the culvert is inconsequential as long as the above conditions are met. This condition is a common occurrence for culverts in rolling or hilly country. The control is critical depth at the entrance for HW values up to about 1.5D. Control is the entrance geometry for HW values over about 1.5D. HW is determined from empirical curves in the form of nomographs that are discussed later in this chapter. If TW is greater than D, outlet velocity is based on full flow at the outlet. If TW is less than D, outlet velocity is based on uniform depth for the culvert.

### 4.6.3.3 Slug Flow

**Inlet or Outlet Control** — For "slug" flow operation the entrance may be submerged or unsubmerged, critical depth is greater than uniform depth at the design discharge ( $d_c > d_u$ ), TW depth is greater than  $(SL + d_c)$  (TW elevation is above the critical depth at the entrance), and TW depth is less than  $SL + D$  (TW elevation is below the upstream soffit). TW depth with respect to D alone is inconsequential as long as the above conditions are met. This condition is a common occurrence for culverts in rolling or hilly country. The control for this type of operation may be at the entrance or the outlet, or control may transfer itself back and forth between the two (commonly called "slug" flow). For this reason, it is recommended that HW be determined for both entrance control and outlet control and the higher of the two determinations be used. Entrance control HW is determined from the inlet control nomographs and outlet control HW is determined by Equations 4.3, 4.4, or the outlet control nomographs.

If TW depth is less than D, outlet velocity should be based on TW depth. If TW depth is greater than D, outlet velocity should be based on full flow at the outlet.

## 4.7 Design Procedures

### 4.7.1 Procedures

There are two procedures for designing culverts described in this chapter: (1) the manual use of inlet and outlet control nomographs and (2) use of the FHWA HY8 Culvert Analysis Microcomputer Program.

It is recommended that the HYDRAIN Culvert Computer Program be used for HY8 culvert design since it will allow the engineer to easily develop performance curves to examine more than one design situation. HYDRAIN uses the theoretical basis for the nomographs to size a culvert. In addition, this system can evaluate improved inlets, route hydrographs, consider road overtopping, and evaluate outlet streambed scour. By using water surface profiles, this procedure is more accurate than manual methods in predicting backwater effects and outlet scour.

The following outlines the design procedures for use of the nomograph. The user is directed to the Federal Highway Administration Hydraulic Design Series No. 5 for additional information. Use of the computer model is discussed later in this Chapter. HECRAS, or other computer programs may be used if approved, in advance, by the City Department of Public Works.

### 4.7.2 Tailwater Elevations

In some cases, culverts fail to perform as intended because of tailwater elevations high enough to create backwater. The problem is more severe in areas where gradients are very flat, and in some cases in areas with moderate slopes. Thus, as part of the design process, the normal depth of flow in the downstream channel at discharges equal to those being considered should be computed.

If the tailwater computation leads to water surface elevations below the invert of the culvert exit, there are obviously no problems; if elevations above the culvert invert are computed, the culvert capacity will be somewhat less than assumed. The tailwater computation can be simple, and on steep slopes requires little more than the determination of a cross section downstream where normal flow can be assumed, and a Manning equation calculation. (See Chapter 5 for more information on open channel analysis.) Conversely, with sensitive flood hazard sites, if the slopes are flat, or natural and man-made obstructions exist downstream, a water surface profile analysis reaching beyond these obstructions may be required.

### 4.7.3 Culvert Design Nomographs

The use of culvert design nomographs requires a trial and error solution. The solution provides reliable designs for many applications. It should be remembered that velocity, hydrograph routing, roadway overtopping, and outlet scour require additional, separate computations beyond what can be obtained from the nomographs.

Figures 4-2 and 4-3 show examples of an inlet control and outlet control nomograph that can be used to design concrete pipe culverts. For culvert designs not covered by these nomographs, refer to the set of nomographs given in Appendix 4-A at the end of this chapter.

## 4.7.4 Steps in the Design Procedure

The design procedure requires the use of inlet and outlet nomographs.

### Step Action

(1) List design data:

Q	=	discharge (cfs)
L	=	culvert length (ft.)
S	=	culvert slope (ft./ft.)
HW	=	allowable headwater depth for the design storm (ft.)
V	=	velocity for trial diameter (ft./s.)
$K_e$	=	inlet loss coefficient
TW	=	tailwater depth (ft.)

(2) Determine trial culvert size by assuming a trial velocity 3 to 5 ft./s. and computing the culvert area,

$$A = Q/V. \text{ Determine the culvert diameter (in.).}$$

(3) Find the actual HW for the trial size culvert for both inlet and outlet control.

- For inlet control, enter inlet control nomograph with D and Q and find HW/D for the proper entrance type.
- Compute HW and, if too large or too small, try another culvert size before computing HW for outlet control.
- For outlet control, enter the outlet control nomograph with the culvert length, entrance loss coefficient, and trial culvert diameter.
- To compute HW, connect the length scale for the type of entrance condition and culvert diameter scale with a straight line, pivot on the turning line, and draw a straight line from the design discharge through the turning point to the head loss scale H. Compute the headwater elevation HW from the equation:

$$\mathbf{HW = H + h_o - LS} \quad \mathbf{(4.5)}$$

Where:  $h_o = 1/2$  (critical depth + D), or tailwater depth, whichever is greater.

(4) Compare the computed headwaters and use the higher HW to determine if the culvert is under inlet or outlet control.

If outlet control governs and the HW is unacceptable, select a larger trial size and find another HW with the outlet control monographs. Since the smaller size of culvert had been selected for allowable HW by the inlet control monographs, the inlet control for the larger pipe need not be checked.

(5) Calculate exit velocity and expected streambed scour to determine if an energy dissipater is needed. See Chapter 7.

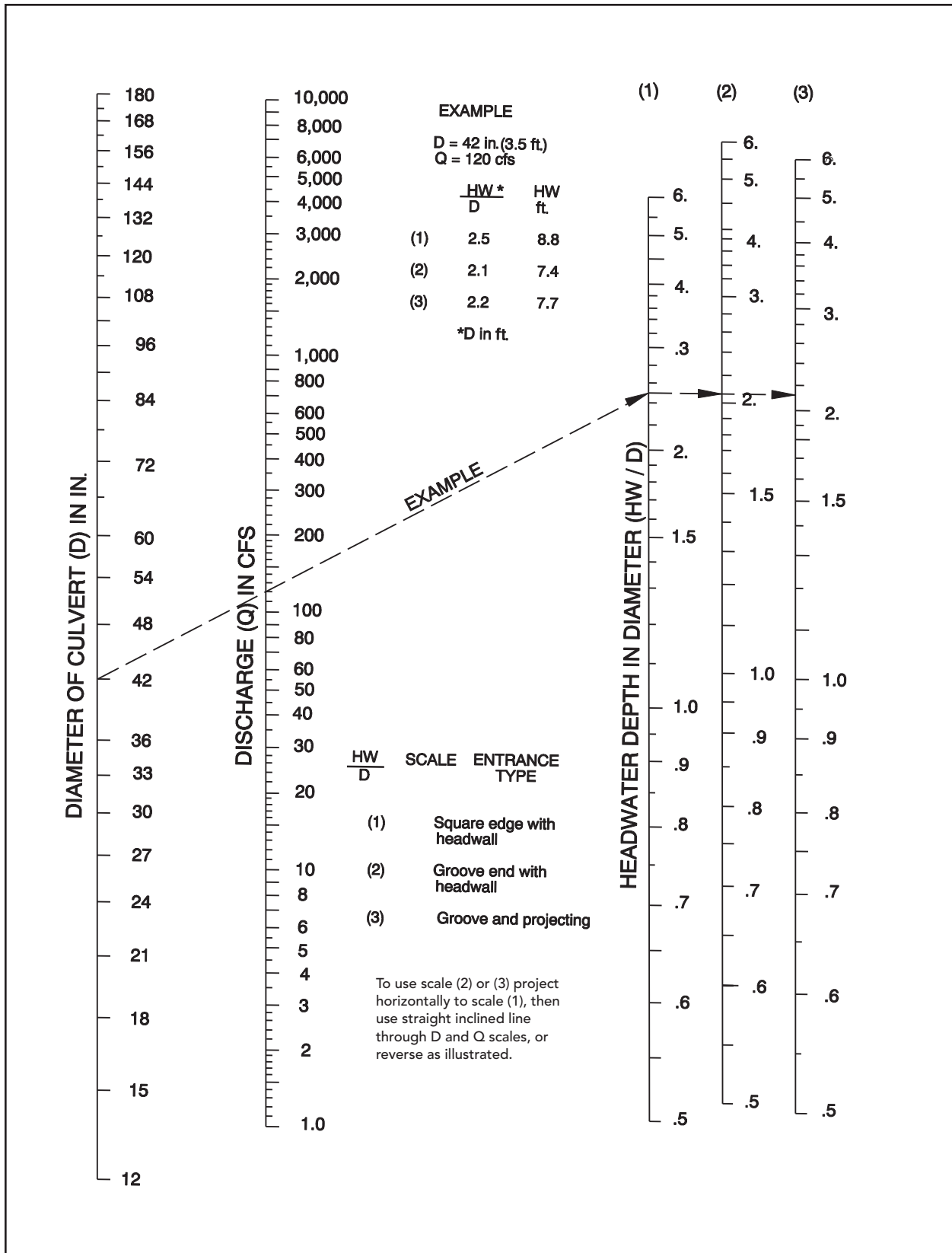

Figure 4-2 Headwater Depth for Concrete Pipe Culverts with Inlet Control

Source: Bureau of Public Roads, Jan 1963  
 Headwater Scales 2 & 3, Revised May 1964

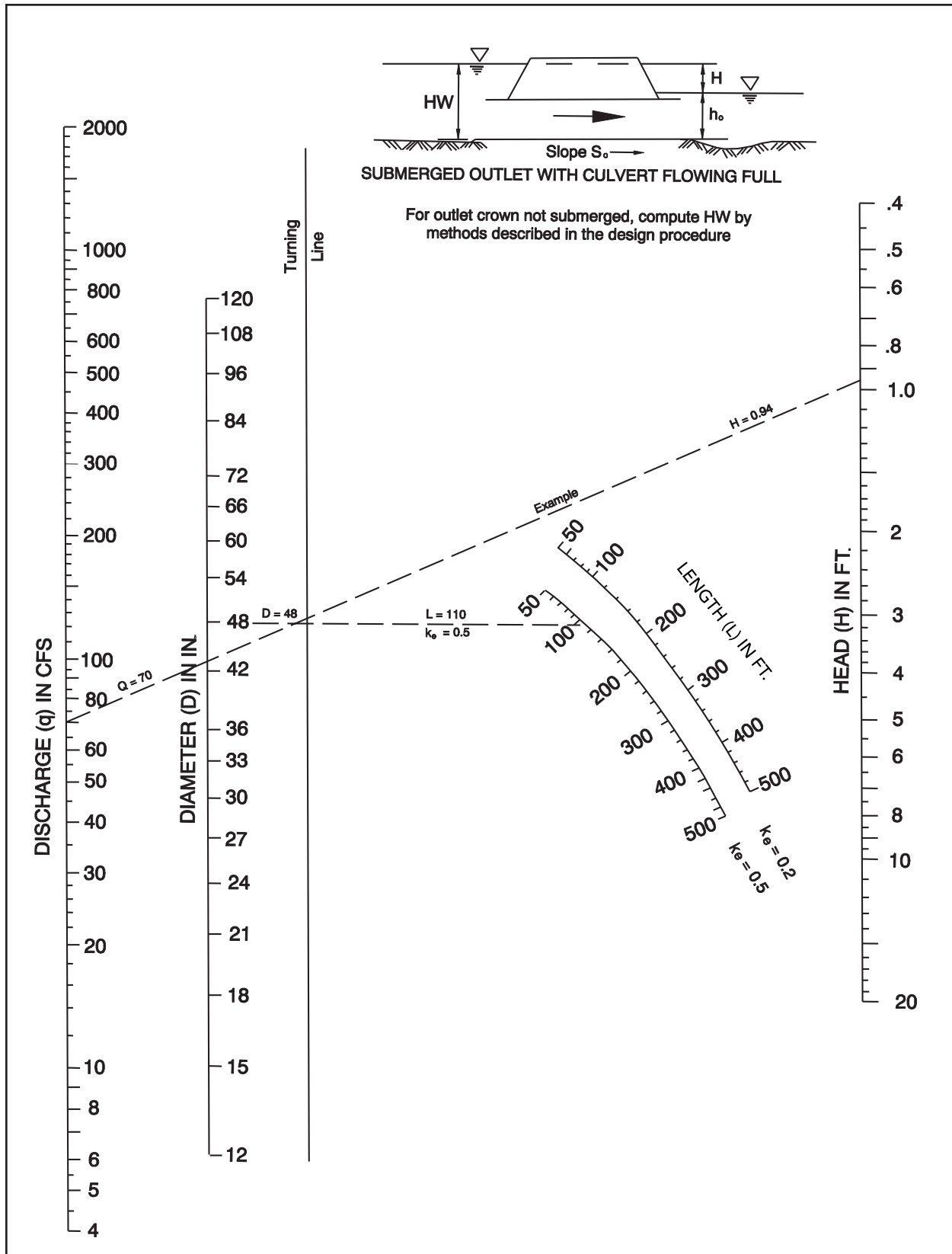

Figure 4-3 Head for Concrete Pipe Culverts Flowing Full (n = 0.012)

Source: Bureau of Public Roads, Jan 1963

## 4.7.5 Performance Curves

A performance curve for any culvert can be obtained from the nomographs by repeating the steps outlined above for a range of discharges that are of interest for that particular culvert design. A graph is then plotted of headwater vs. discharge with sufficient points so that a curve can be drawn through the range of interest. These curves are applicable through a range of headwater, velocities, and scour depths versus discharges for a length and type of culvert. Usually charts with length intervals of 25 to 50 ft. are satisfactory for design purposes. Such computations are made much easier by the computer program discussed in [Section 4.11](#) of this manual.

## 4.7.6 Roadway Overtopping

To complete the culvert design, roadway overtopping should be analyzed. See [Section 4.5.9](#). A performance curve showing the culvert flow as well as the flow across the roadway is a useful analysis tool. Rather than using a trial and error procedure to determine the flow division between the overtopping flow and the culvert flow, an overall performance curve can be developed.

The overall performance curve can be determined as follows:

### Step Action

- (1) Select a range of flow rates and determine the corresponding headwater elevations for the culvert flow alone. The flow rates should fall above and below the design discharge and cover the entire flow range of interest. Both inlet and outlet control headwaters should be calculated.
- (2) Combine the inlet and outlet control performance curves to define a single performance curve for the culvert.
- (3) When the culvert headwater elevations exceed the roadway crest elevation, overtopping will begin. Calculate the equivalent upstream water surface depth above the roadway (crest of weir) for each selected flow rate. Use these water surface depths and Equation 4.6 to calculate flow rates across the roadway.

$$Q = C_d L (HW)^{1.5} \quad (4.6)$$

Where:

- Q = overtopping flow rate (ft.<sup>3</sup>/s.)
- C<sub>d</sub> = overtopping discharge coefficient
- L = length of roadway (ft.)
- HW = upstream depth, measured from the roadway crest to the water surface upstream of the weir drawdown (ft.)

Note: See [Figure 4-4](#) for guidance in determining a value for C<sub>d</sub>. For more information on calculating overtopping flow rates see pages 39 - 42 in FHWA HDS No. 5.

- (4) Add the culvert flow and the roadway overtopping flow at the corresponding headwater elevations to obtain the overall culvert performance curve.

### 4.7.7 Storage Routing

A significant storage capacity behind a roadway embankment may attenuate a flood hydrograph. Because of the reduction of the peak discharge associated with such attenuation, the required capacity of the culvert, and its size, may be reduced. If significant storage is anticipated behind a culvert, the design may be checked by routing the design hydrographs through the culvert to determine the discharge and stage behind the culvert. Routing procedures are outlined in Hydraulic Design of Highway Culverts, Section V — Storage Routing, FHWA HDS No. 5. If credit for storage attenuation is taken in designing a culvert, the facility should be designed as a detention pond and measures should be taken to ensure the area inundated by floodwater is not encroached upon in the future.

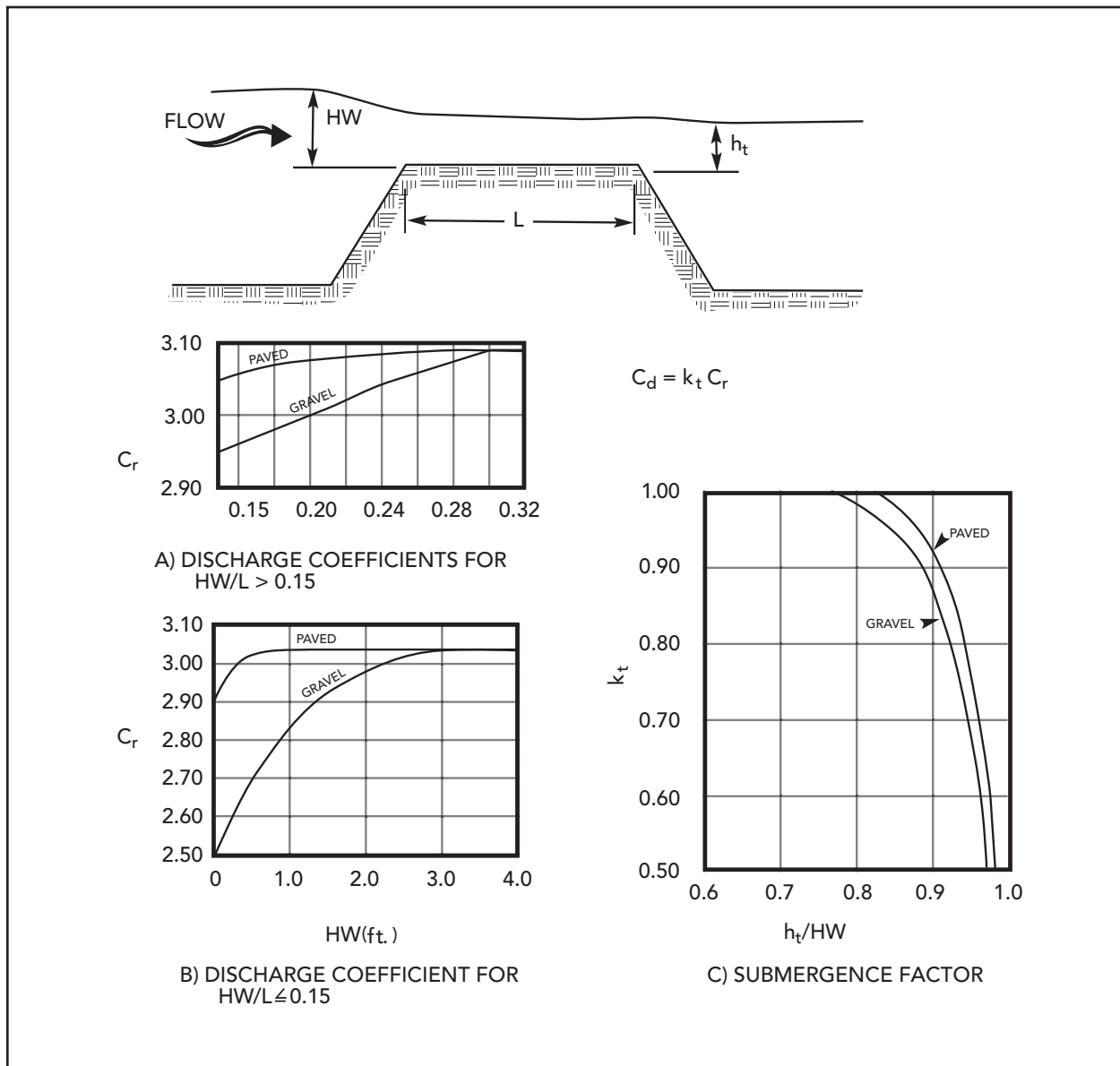

Figure 4-4 Discharge Coefficients for Roadway Overtopping



5. The culvert is checked for outlet control by using [Figure 4-3](#).

With an entrance loss coefficient  $K_e$  of 0.20 (see [Table 4-2](#)), a culvert length of 100 ft., and a pipe diameter of 48 in., an  $H$  value of 1.08 ft. is determined. The headwater for outlet control is computed by the equation:

$$HW = H + h_o - LS$$

For the tailwater depth lower than the top of culvert,

$h_o = TW$  or  $1/2$  (critical depth in culvert +  $D$ ) whichever is greater.

From [Appendix 4-B](#), the critical depth for a 4.0 ft. diameter circular pipe is 2.7 ft.

$$h_o = 3.0 \text{ ft. or } h_o = 1/2 (2.7 + 4.0) = 3.35 \text{ ft.}$$

The headwater depth for outlet control is:

$$HW = H + h_o - LS = 1.08 + 3.35 - (100) \times (0.0015) = 4.28 \text{ ft.}$$

6. Since HW for outlet control (4.28 ft.) is greater than the HW for inlet control (4.08 ft.), outlet control governs the culvert design.

Thus, the maximum headwater expected for a 50-year recurrence flood is 4.28 ft., which is less than the allowable headwater of 4.3 ft.

7. The performance of the culvert is checked for the 100-year discharge.

The allowable headwater for a 100-year discharge is 5.0 ft.; critical depth in the 48 in. diameter culvert for the 100-year discharge is 3.1 ft.

For outlet control, an  $H$  of 1.8 is read from the outlet control nomograph.

The maximum headwater is:

$$HW = H + h_o - LS = 1.8 + 4.0 - (100) \times (0.0015) = 5.65 \text{ ft.}$$

This depth is greater than the allowable depth of 5.0 ft., thus a larger size culvert must be selected.

8. A 54 in. diameter culvert is tried and found to have a maximum headwater depth of 4.16 ft. for the 50-year discharge and a maximum headwater depth of 4.95 ft. for the 100-year discharge. These values are acceptable for the design conditions.
9. Estimate outlet exit velocity. Since this culvert is on outlet control and discharges into an open channel downstream, the culvert will be flowing full at the flow depth in the channel. Using the 100-year design peak discharge of 105 cfs and the area of a 54 in. or 4.5 ft. diameter culvert, the exit velocity will be:

$$V = Q/A = 105 / (3.14 (4.5)^2)/4 = 6.6 \text{ ft./s.}$$

With this velocity, some energy dissipater is needed downstream from this culvert for stream bank protection. See Chapter 7, Energy Dissipaters for design procedures related to energy dissipaters.

10. Design engineers should check minimum velocities for low frequency flows if the larger storm event (100-year) controls culvert design.

Figure 4-5 provides a convenient form to organize culvert design calculations.

For an example of a design which incorporates roadway overtopping, see Appendix 4-D.



## 4.9 Design of Improved Inlets

### 4.9.1 Introduction

A culvert operates in either inlet or outlet control. As previously discussed under outlet control, headwater depth, tailwater depth, entrance configuration, and barrel characteristics all influence a culvert's capacity.

The entrance configuration is defined by the barrel cross sectional area, shape, and edge condition, while the barrel characteristics are area, shape, slope, length, and roughness.

### 4.9.2 Outlet Control

The flow condition for outlet control may be full or partly full for all or part of the culvert length. The design discharge usually results in full flow. Inlet improvements in these culverts reduce the entrance losses, which are only a small portion of the total headwater requirements. Therefore, only minor modifications of the inlet geometry which result in little additional cost are justified.

### 4.9.3 Inlet Control

In inlet control, only entrance configuration and headwater depth determine the culvert's hydraulic capacity. Barrel characteristics and tail water depth are of no consequence. These culverts usually lie on relatively steep slopes and flow only partly full. Entrance improvements can result in full, or nearly full flow, thereby increasing culvert capacity significantly.

### 4.9.4 Common Entrances

The figure on the next page illustrates the performance of a 30 in. circular culvert in inlet control with three commonly used entrances: thin-edged projecting, square-edged, and groove edged.

### 4.9.5 Capacity Determinations

It is clear that inlet type and headwater depth determine the capacities of many culverts. For a given headwater, a groove-edged inlet has a greater capacity than a square edged inlet, which in turn performs a thin-edged projecting inlet.

The performance of each inlet type is related to the degree of flow contraction. A high degree of contraction requires more energy, or headwater, to convey a given discharge than a low degree of contraction

### 4.9.6 Improved Inlets

Improved inlets include inlet geometry refinements beyond those normally used in conventional culvert design practice. Several degrees of improvements are possible, including bevel edged, side-tapered, and slope tapered inlets.

#### 4.9.6.1 Bevel-Edged Inlet

The first degree of inlet improvement is a beveled edge. The bevel is proportioned based on the culvert barrel or face dimension and operates by decreasing the flow contraction at the inlet (see [Figure 4-6](#)). A bevel is similar to a chamfer except that a chamfer is smaller and is generally used to prevent damage to sharp concrete edges during construction.

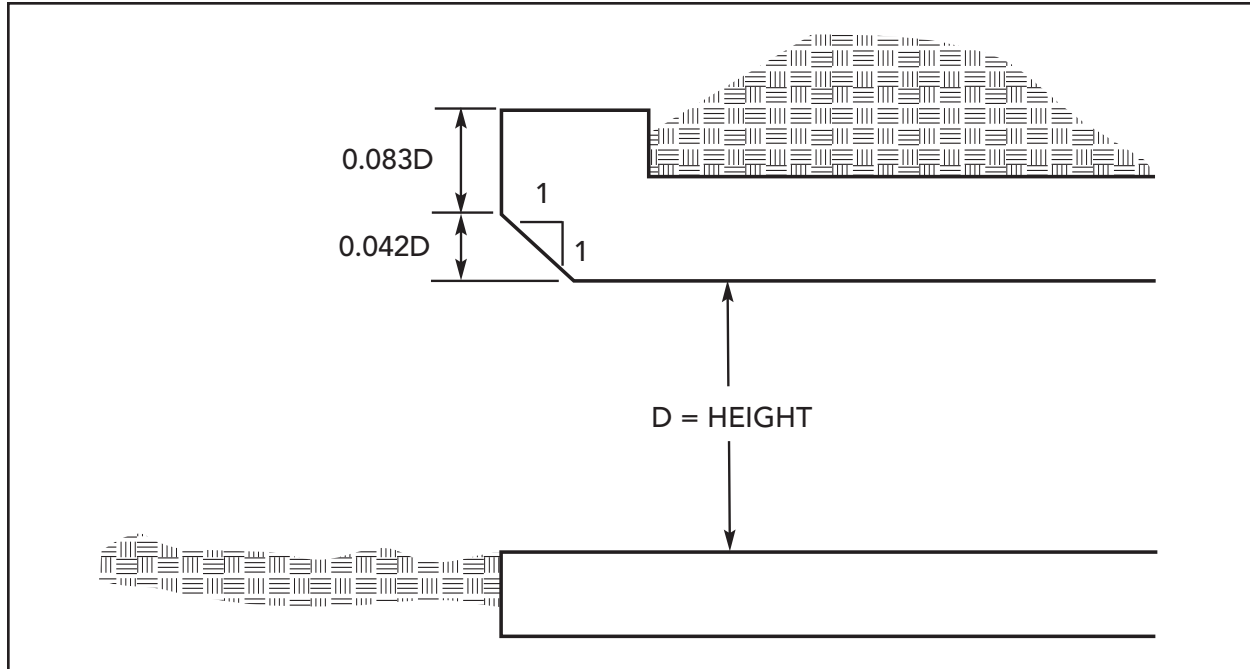

**Figure 4-6 Beveled Edged Inlet**

Adding bevels to a conventional culvert design with a square-edged inlet increases culvert capacity by 5 to 20 percent. The higher increase results from comparing a bevel-edged inlet with a square-edged inlet at high headwaters. The lower increase is the result of comparing inlets with bevels, with structures having wingwalls of 30 to 45 degrees. Although the bevels referred to in this publication are plane surfaces, rounded edges which approximate the bevels are also acceptable.

As a minimum, bevels should be used on all culverts which operate in inlet control, both conventional and improved inlet types. The exception to this is circular concrete culverts where the socket end performs much the same as a beveled edge.

Culverts flowing in outlet control cannot be improved as much as those in inlet control, but the entrance loss coefficient,  $k_e$ , is reduced from 0.5 for a square edge to 0.2 for beveled edges.

It is recommended that bevels be used on all culvert entrances if little additional cost is involved.

#### 4.9.6.2 Side-Tapered Inlet

The second degree of improvement is a side tapered inlet. This inlet has an enlarged face area with the transition to the culvert barrel accomplished by tapering the sidewalls. The inlet face has the same height as the barrel, and its top and bottom are extensions of the top and bottom of the barrel. The intersection of the sidewall tapers and barrel is defined as the throat section. If a headwall and wingwalls are going to be used at the culvert entrance, side-tapered inlets should add little if any to the overall cost while significantly increasing hydraulic efficiency.

The side-tapered inlet provides an increase in flow capacity of 25 to 40 percent over that of a conventional culvert with a square-edged inlet.

Whenever increased inlet efficiency is needed or when a headwall and wingwalls are planned to be used for a culvert installation, a side-tapered inlet should be considered.

### 4.9.6.3 Slope-Tapered Inlet

A slope-tapered inlet is the third degree of improvement. Its advantage over the side tapered inlet without a depression is that more head is available at the inlet. This is accomplished by incorporating a fall in the enclosed entrance section.

The slope-tapered inlet can have over a 100 percent greater capacity than conventional culvert with square edges. The degree of increased capacity depends largely upon the amount of fall available. Since this fall may vary, a range of increased capacities is possible.

Side- and slope-tapered inlets should be used in culvert design when they can economically be used to increase the inlet efficiency over a conventional design.

For a complete discussion of tapered inlets, including figures and illustrations, see FHWA HDS-5, 1985.

### 4.9.6.4 Improved Inlet Performance

The two tables below compare the inlet control performance of the different inlet types. The first half of [Table 4-4](#) shows the increase in discharge that is possible for a headwater depth of 8 ft. The bevel edged inlet, side-tapered inlet and slope-tapered inlet show increases in discharge over the square-edged inlet of 16.7, 30.4 and 55.6 percent, respectively. It should be noted that the slope-tapered inlet incorporates only a minimum fall. Greater increases in capacity are often possible if a larger fall is used.

The second half of [Table 4-4](#) depicts the reduction in headwater that is possible for a discharge of 500 cfs. The headwater varies from 12.5 ft. for the square-edged inlet to 7.6 ft. for the slope-tapered inlet. This is a 39.2 percent reduction in required headwater.

**Table 4-4 Comparison Of Inlet Performance**

Comparison of Inlet Performance at Constant Headwater for 6 ft. x 6 ft. Concrete Box Culvert**			
Inlet Types	Headwater	Discharge	% Improvement
Square edge	8.0 ft.	336 cfs	0
Bevel edge	8.0 ft.	392 cfs	16.7
Side tapered	8.0 ft.	438 cfs	30.4
Slope tapered*	8.0 ft.	523 cfs	55.6
Comparison of Inlet Performance at Constant Discharge for 6 ft. x 6 ft. Concrete Box Culvert**			
Inlet Types	Discharge	Headwaters	% Improvement
Square edge	500 cfs	12.5 ft.	0
Bevel edge	500 cfs	10.1 ft.	19.2
Side tapered	500 cfs	8.8 ft.	29.6
Slope tapered*	500 cfs	7.6 ft.	39.2

\* Minimum fall in inlet =  $D/4 = 6/4 = 1.5$  ft.

\*\* Substantially less improvement in capacity can be accomplished if the culvert functions under outlet control.

## 4.10 Design Procedures for Beveled-Edged Inlets

### 4.10.1 Introduction

This section will outline the procedures and charts to use when incorporating bevel edged inlets in the design of culverts. Those designers interested in using side- and slope-tapered inlets should consult the detailed design criteria and example designs outlined in the U. S. Department of Transportation publication Hydraulic Engineering Circular No. 5 entitled, “Hydraulic Design of Highway Culverts.”

### 4.10.2 Design Figures

Four inlet control figures for culverts with beveled edges are included in [Appendix 4-C](#) at the end of this chapter.

Figure	Use for
4-C-1	circular pipe culverts with beveled ring
4-C-2	rectangular box culverts with 90° headwalls
4-C-3	single barrel box culverts with skewed headwalls
4-C-4	rectangular box culverts with flared wingwalls (18 to 45 degrees)

### 4.10.3 Design Procedure

The figures for bevel-edged inlets are used for design in the same manner as the conventional inlet design nomographs discussed earlier.

Note that Figures 4-C-2, 4-C-3, and 4-C-4 apply only to bevels having either a 33.7 degree angle (1.5:1) or a 45 degree angle (1:1).

For box culverts, the dimensions of the bevels to be used are based on the culvert’s dimensions. The top-bevel dimension is determined by multiplying the height of the culvert by a factor. The side-bevel dimensions are determined by multiplying the width of the culvert by a factor. For a 1:1 bevel, the factor is 1/2 in./ft. For a 1.5:1 bevel the factor is 1 in./ft.

For example the minimum bevel dimensions for a 8 ft. x 6 ft. box culvert with 1:1 bevels would be:

$$\begin{aligned} \text{Top Bevel} &= d = 6 \text{ ft.} \times 1/2 \text{ in./ft.} = 3 \text{ in.} \\ \text{Side Bevel} &= b = 8 \text{ ft.} \times 1/2 \text{ in./ft.} = 4 \text{ in.} \end{aligned}$$

For a 1.5:1 bevel, computations would result in  $d = 6$  and  $b = 8$  in.

### 4.10.4 Design Figure Limits

The improved inlet design figures are based on research results from culvert models with barrel width,  $B$ , to depth,  $D$ , ratios of from 0.5:1 to 2:1.

For box culverts with more than one barrel, the figures are used in the same manner as for a single barrel, except that the bevels must be sized on the basis of the total clear opening rather than on individual barrel size.

For example, in a double 8 ft. by 8 ft. box culvert:

Top Bevel - is proportioned based on the height of 8 ft. which results in a bevel of 4 in. for the 1:1 bevel and 8 in. for the 1.5:1 bevel.

Side Bevel - is proportioned based on the clear width of 16 ft. which results in a bevel of 8 in. for the 1:1 bevel and 16 in. for the 1.5:1 bevel.

### 4.10.5 Area Ratios

The ratio of the inlet face area to the barrel area remains the same as for a single barrel culvert. Multi-barrel pipe culverts should be designed as a series of single barrel installations since each pipe requires a separate bevel.

### 4.10.6 Multi-barrel Installations

For multi-barrel installations exceeding a 3:1 width to depth ratio, the side bevel becomes excessively large when proportioned on the basis of the total clear width. For these structures, it is recommended that the side bevel be sized in proportion to the total clear width,  $B$ , or three times the height, whichever is smaller.

The top bevel dimension should always be based on the culvert height.

The shape of the upstream edge of the intermediate walls of multi-barrel installations is not as important to the hydraulic performance of a culvert as the edge condition of the top and sides. Therefore, the edges of these walls may be square, rounded with a radius of one half their thickness, chamfered, or beveled. The intermediate walls may also project from the face and slope downward to the channel bottom to help direct debris through the culvert.

### 4.10.7 Skewed Inlets

Skewed inlets should be avoided whenever possible, and should not be used with side- or slope-tapered inlets.

## 4.11 HYDRAIN Culvert Computer Program

### 4.11.1 Introduction

The HYDRAIN Culvert Computer Program can be purchased from McTrans Software or Dodson & Associates. It will perform calculations for the following:

1. culvert analysis (including independent multiple barrel sizing)
2. hydrograph generation
3. hydrograph routing
4. roadway overtopping
5. outlet scour estimates

### 4.11.2 User-Friendly Features

HYDRAIN's culvert analysis has several user-friendly features which permit easy data entry, editing and comparison of several design alternatives. Data are entered by selecting options on a menu or by entering numeric data at prompts. These data are periodically summarized in tables. Any incorrect entry can be changed, and design variations can be quickly analyzed. Another feature of HYDRAIN's culvert analysis is that plots of irregular cross sections, channel rating curves and culvert performance curves can be obtained if the terminal has graphics capabilities.

### 4.11.3 Example

The example problem in [Appendix 4-D](#) provides the user with analysis approaches to be used with the culvert analysis portion of the program. The example provides instruction in data entry, file modification and culvert performance analysis. It should be helpful for the user to work through the problem on the computer while following the text so as to become familiar with the program. New users should consult the README file that accompanies the program for further help and directions.

The culvert example was chosen to illustrate the features of the software and does not necessarily represent a cost-effective design. Since program development is ongoing, some of the screens shown in the examples may differ slightly from the version being used for design.

## 4.12 Construction and Maintenance Considerations

An important step in the design process involves identifying whether special provisions are warranted to properly construct or maintain proposed facilities. Culverts located on and aligned with the natural channel generally do not have a sedimentation problem. A stable channel is expected to balance erosion and sedimentation. A culvert resting on such a channel behaves in a similar manner. In a degrading channel, erosion, not sedimentation, is a potential problem. A culvert located in a grading channel may encounter some sedimentation. Multi-barrel culverts and culverts with depressed inlets may encounter sedimentation problems. It is common for one or more barrels to accumulate sediment. Culverts built with an upstream depression have a barrel slope less than the stream slope and sediment accumulation is likely. Both usually are self-cleaning during periods of high discharge. Maintenance concerns of storm sewer system design center on adequate physical access for cleaning and repair.

Culverts must be kept free of obstructions. Sand or sediment deposits should be removed as soon as possible. During major storms, critical areas should be patrolled and the inlets kept free of debris. Inlet and outlet channels should be kept in alignment and vegetation should be controlled in order to prevent any significant restriction of flow. Provision for a smooth, well designed inlet and avoidance of multiple barrels and skewed inlets will help align and pass most floating debris. Preventative maintenance should be used to inspect for structural problems, replacement needs, and scheduling of needed repairs.

(This page was intentionally left blank)

Appendix 4-A  
Culvert Design Nomographs  
(For Outlet and Inlet Controls)

(This page was intentionally left blank)

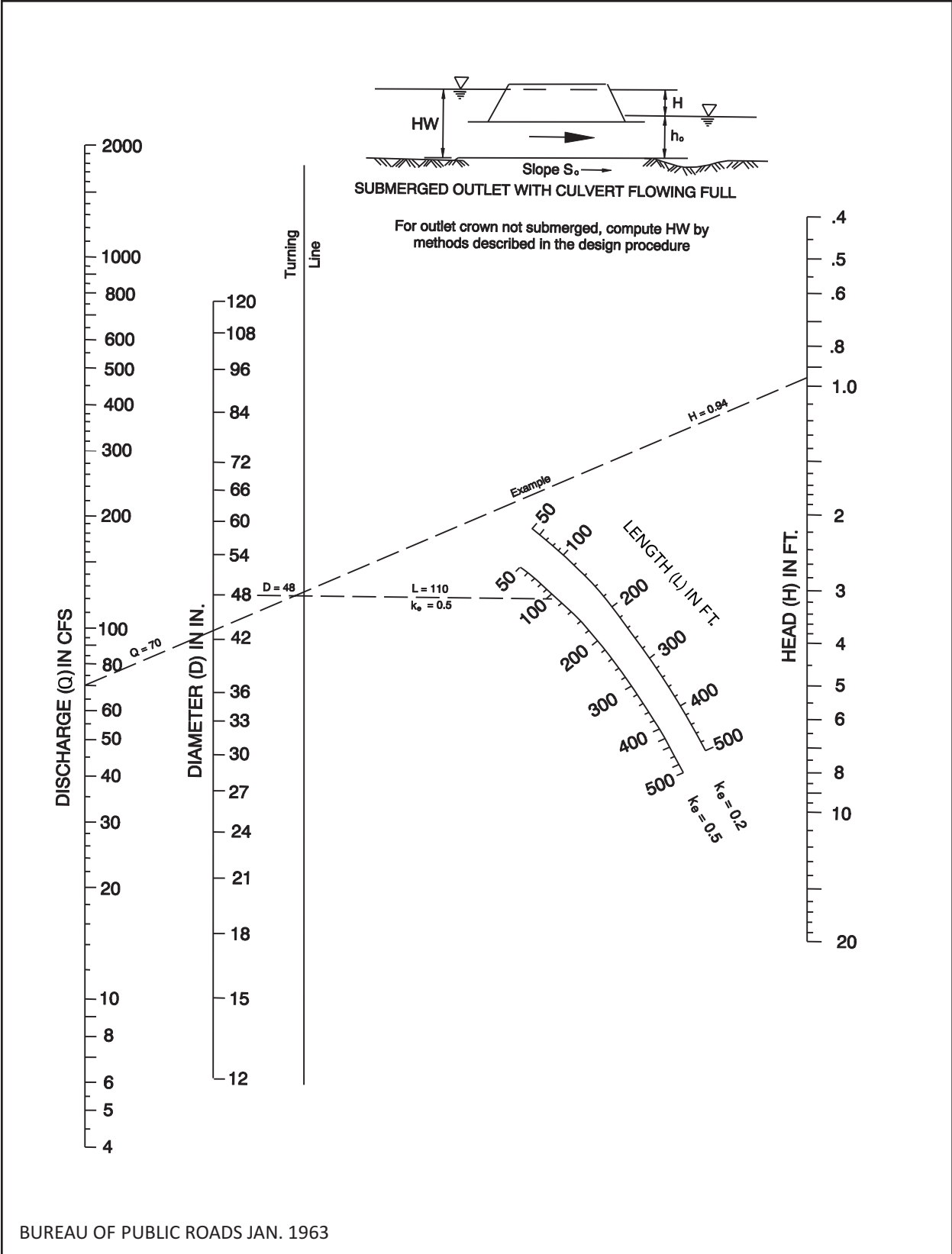

Figure 4-A-1 Head For Concrete Pipe Culverts Flowing Full n = 0.012

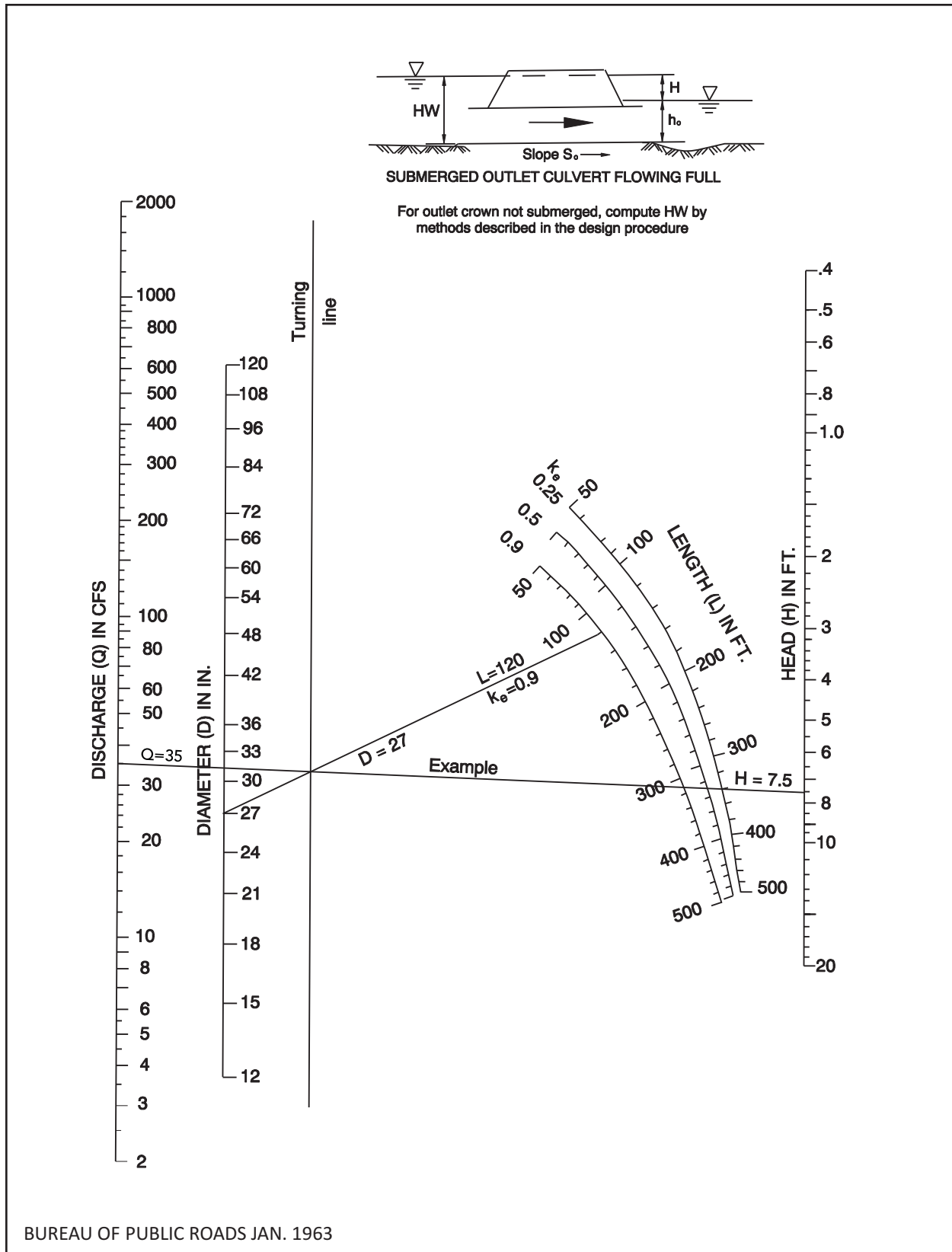

Figure 4-A-2 Head For Standard C. M. Pipe Culverts Flowing Full  $n = 0.024$



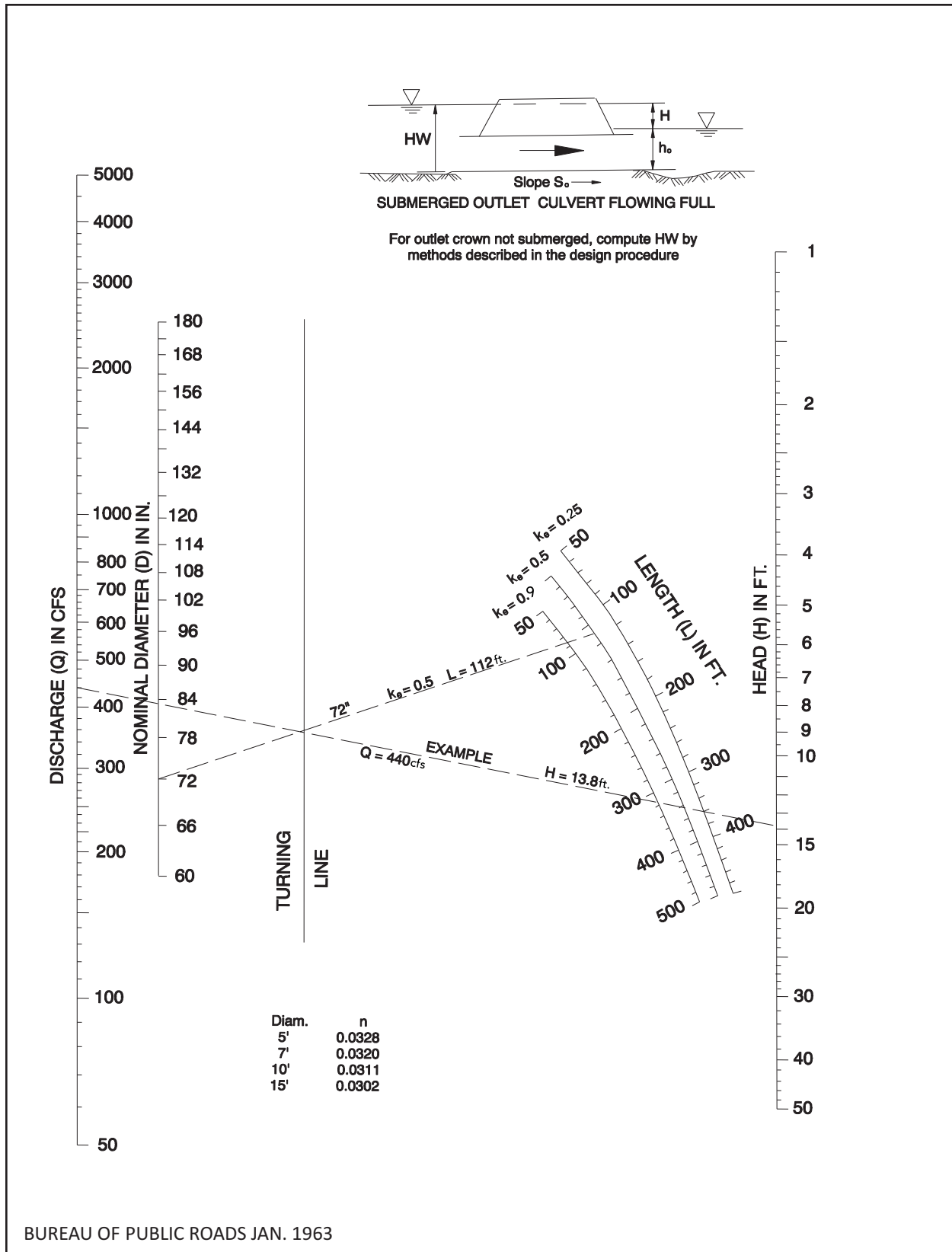

Figure 4-A-4 Head For Structural Plate Corr. Metal Pipe Culverts Flowing Full  $n = 0.0328$  to  $0.0302$

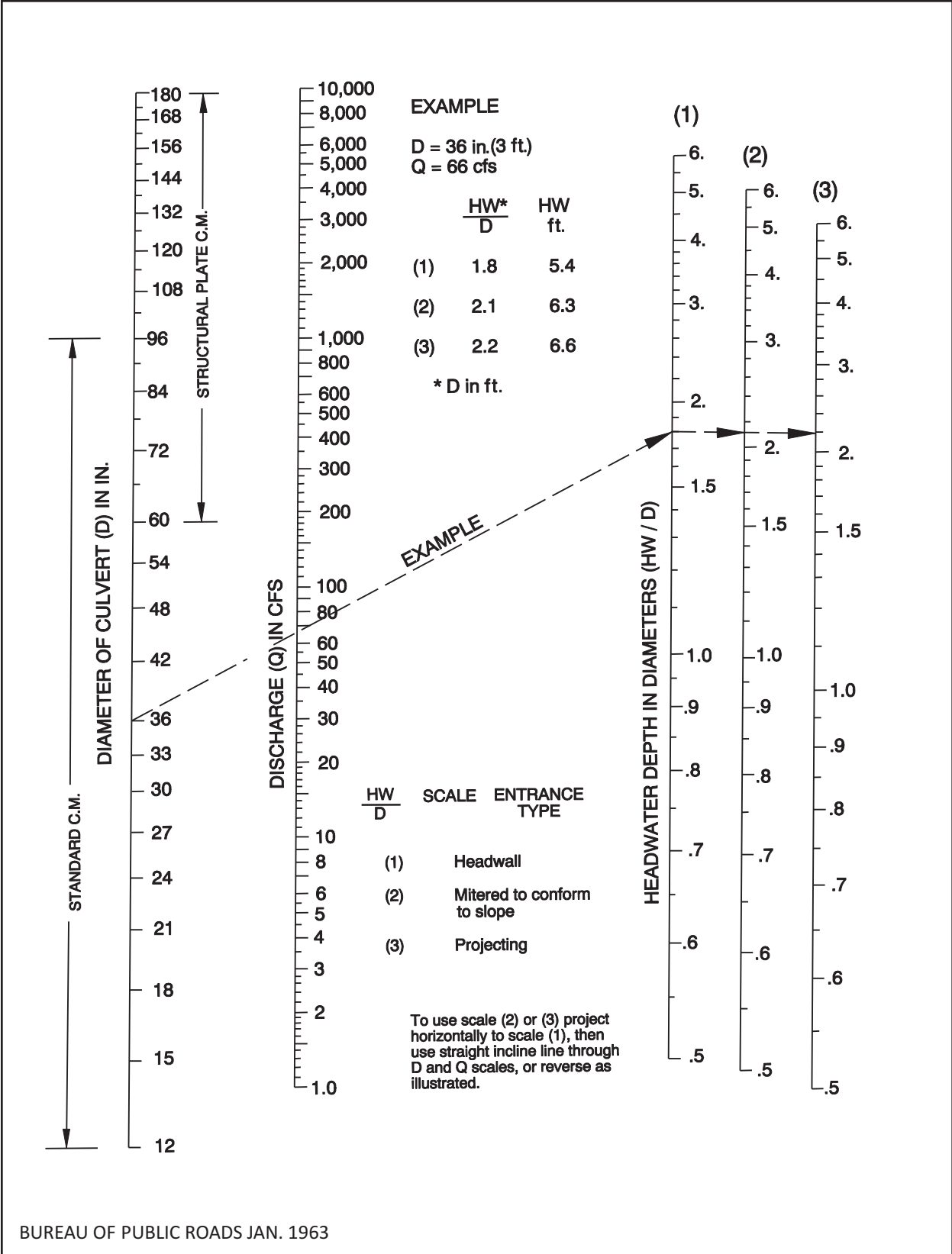

Figure 4-A-5 Headwater Depth For C. M. Pipe Culverts With Inlet Control

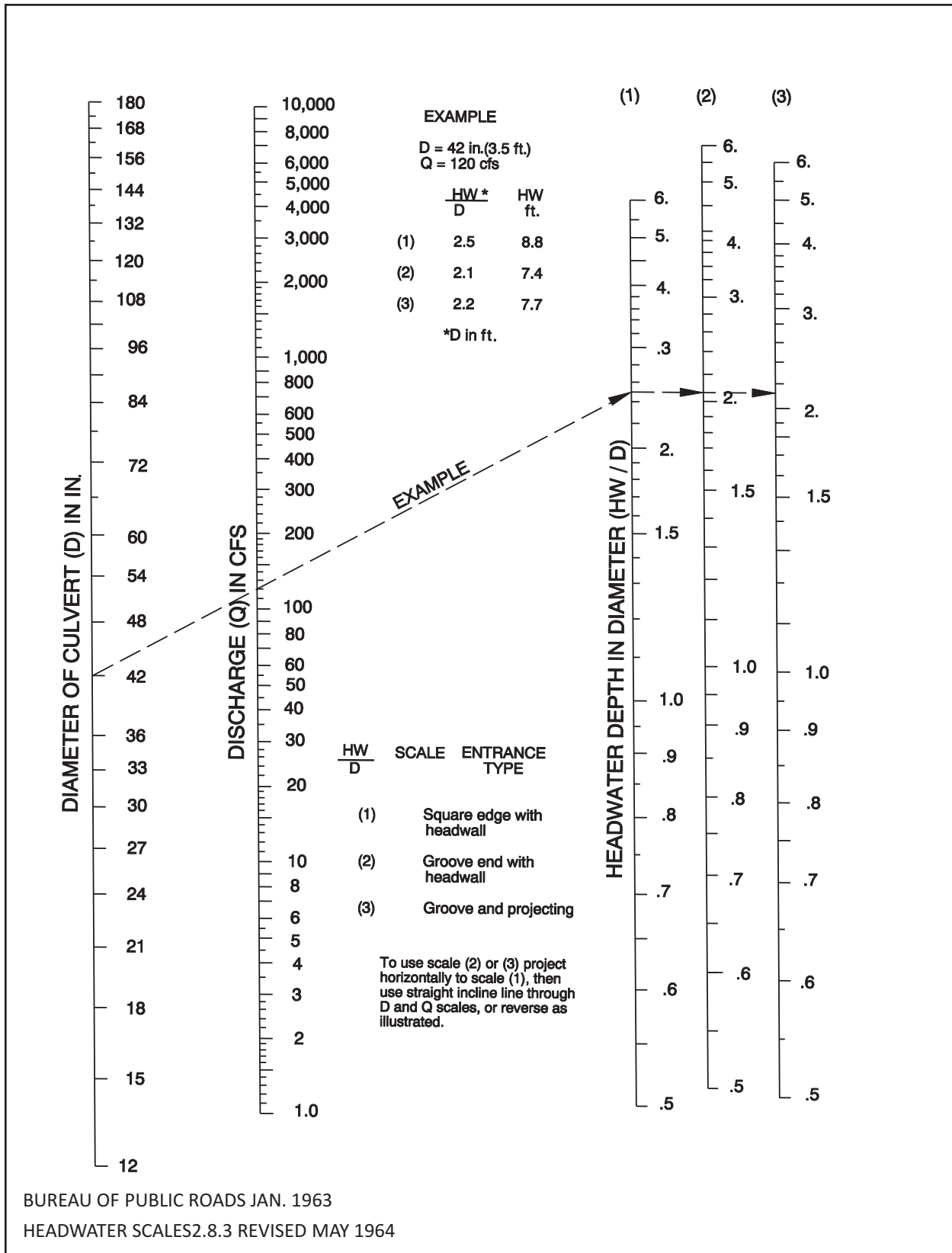

Figure 4-A-6 Headwater Depth For Concrete Pipe Culverts With Inlet Control

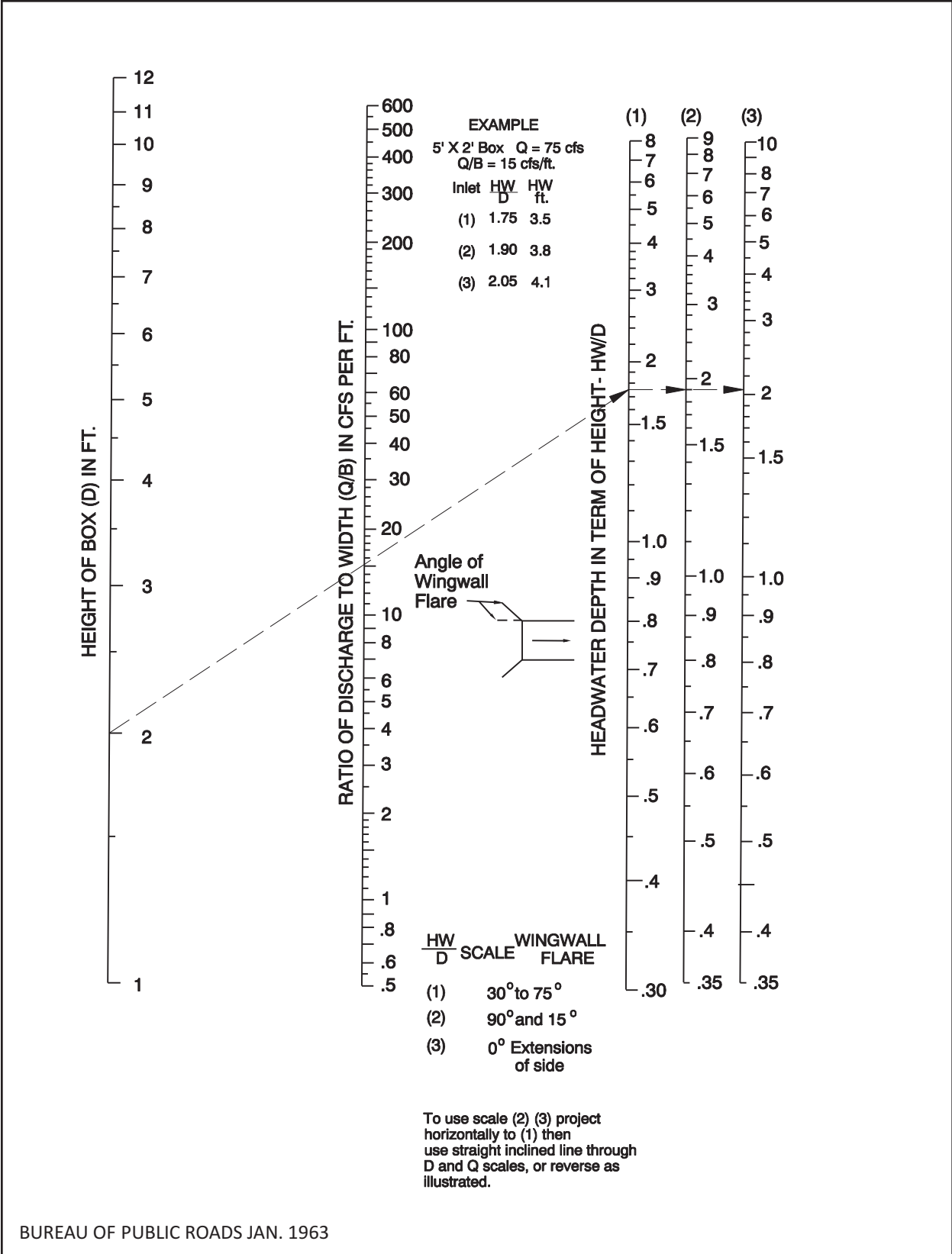

Figure 4-A-7 Headwater Depth For Box Culverts With Inlet Control

(This page was intentionally left blank)

Appendix 4-B  
Critical Depth Charts

(This page was intentionally left blank)

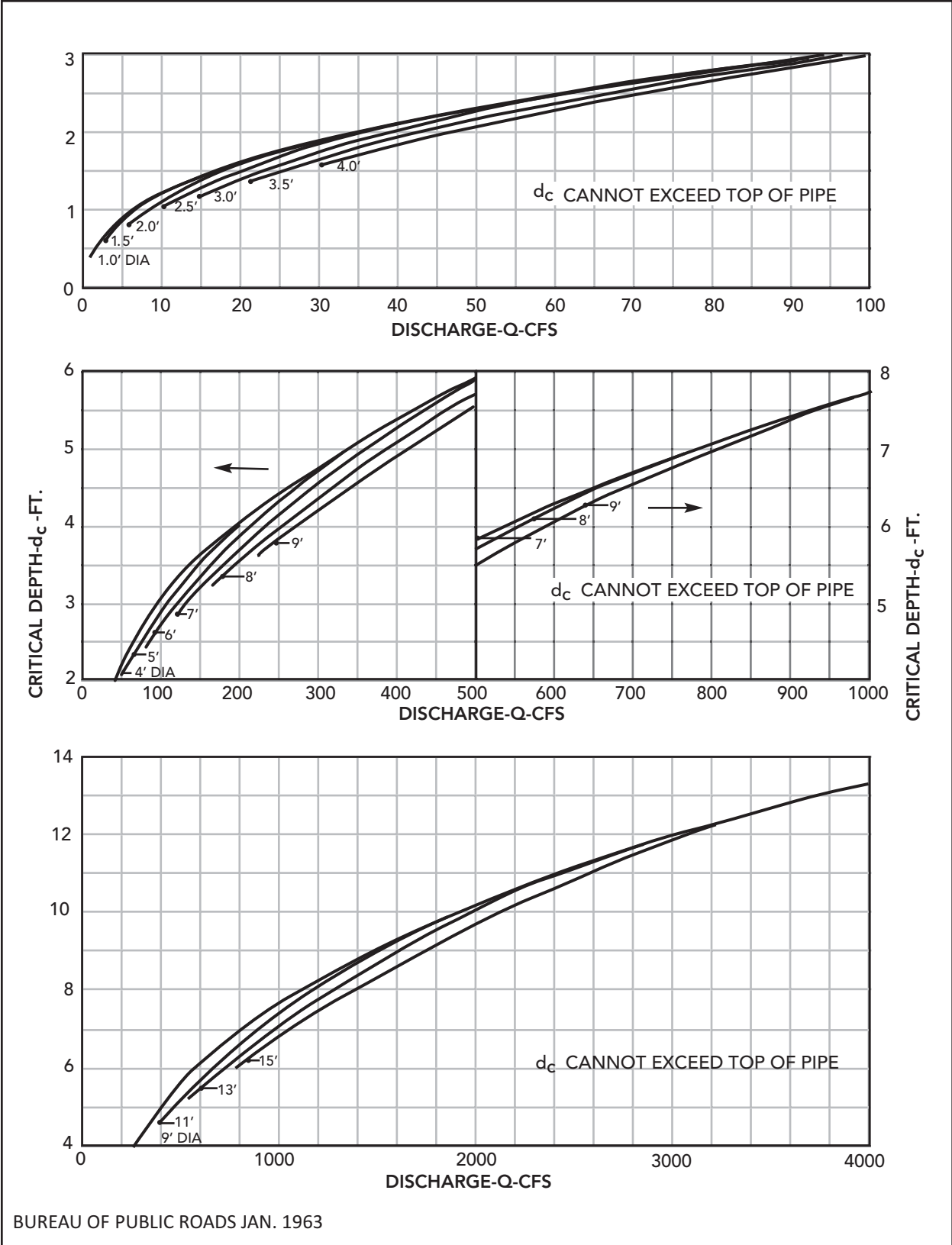

Figure 4-B-1 Critical Depth Circular Pipe

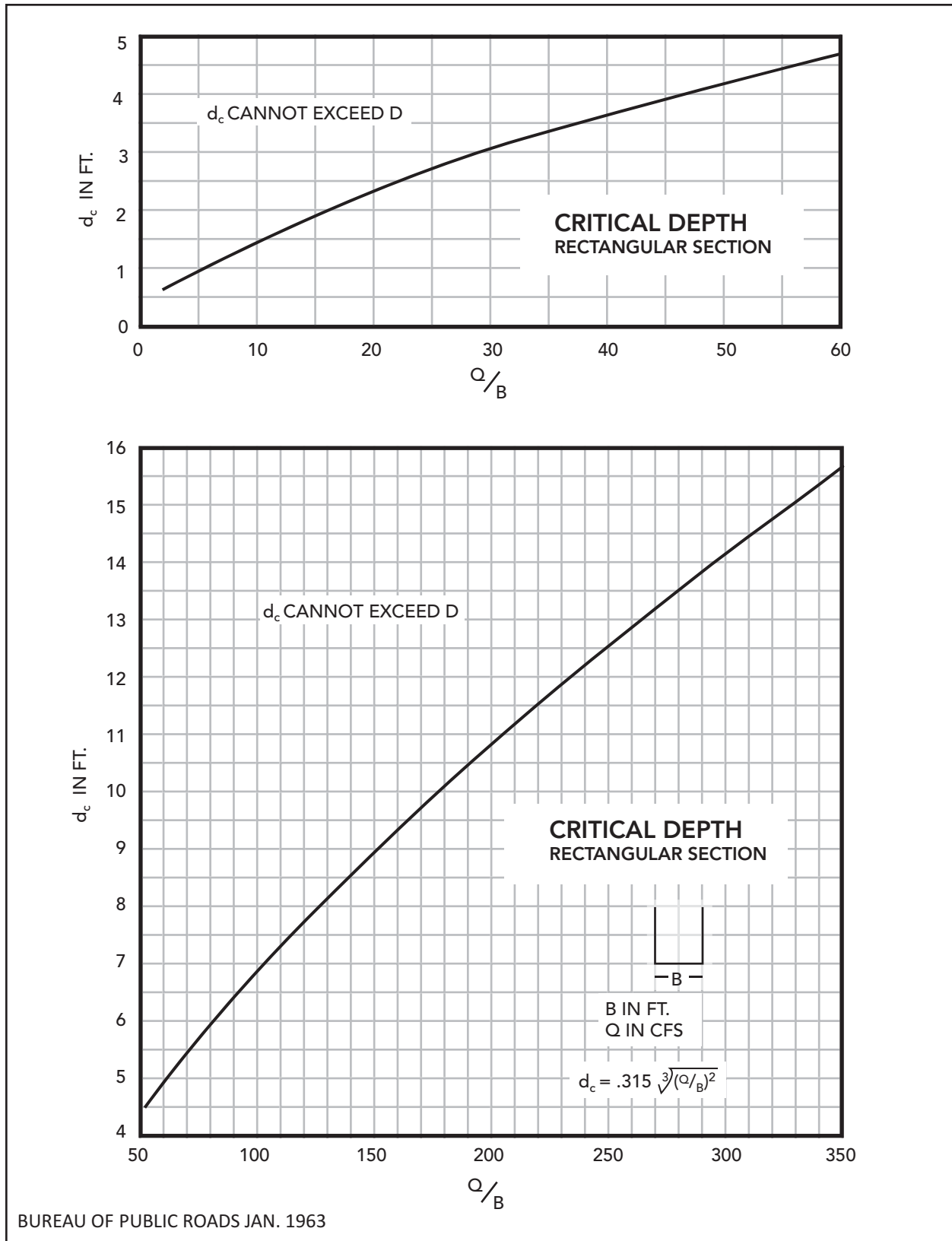

Figure 4-B-2 Critical Depth Rectangular Section

Appendix 4-C  
Inlet Control Design Graphs  
For Improved Inlet Culverts

(This page was intentionally left blank)

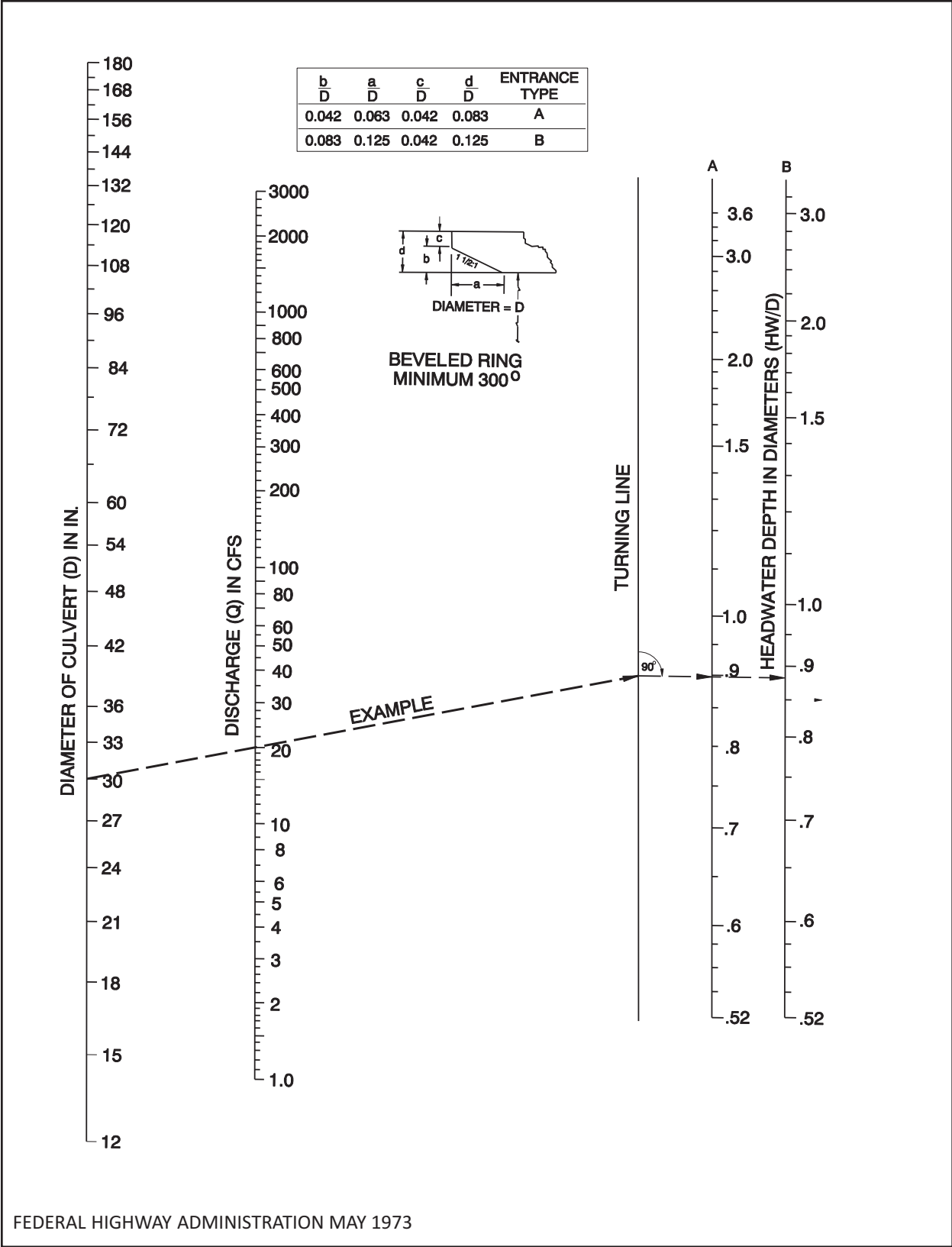

Figure 4-C-1 Headwater Depth For Circular Pipe Culverts With Beveled Ring Inlet Control

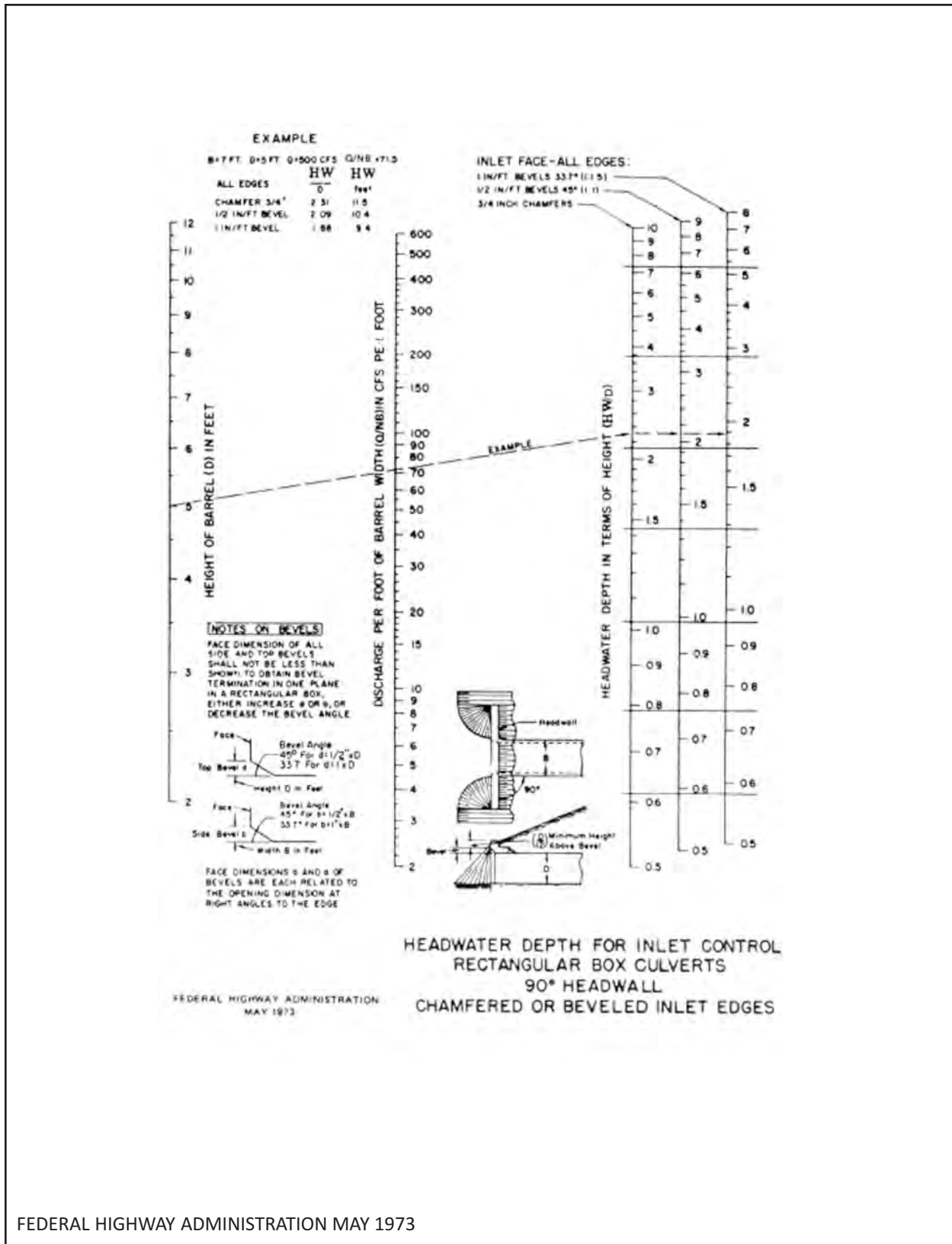

Figure 4-C-2 Headwater Depth For Inlet Control Rectangular Box Culverts  
 90° Headwall Chamfered Or Beveled Inlet Edges

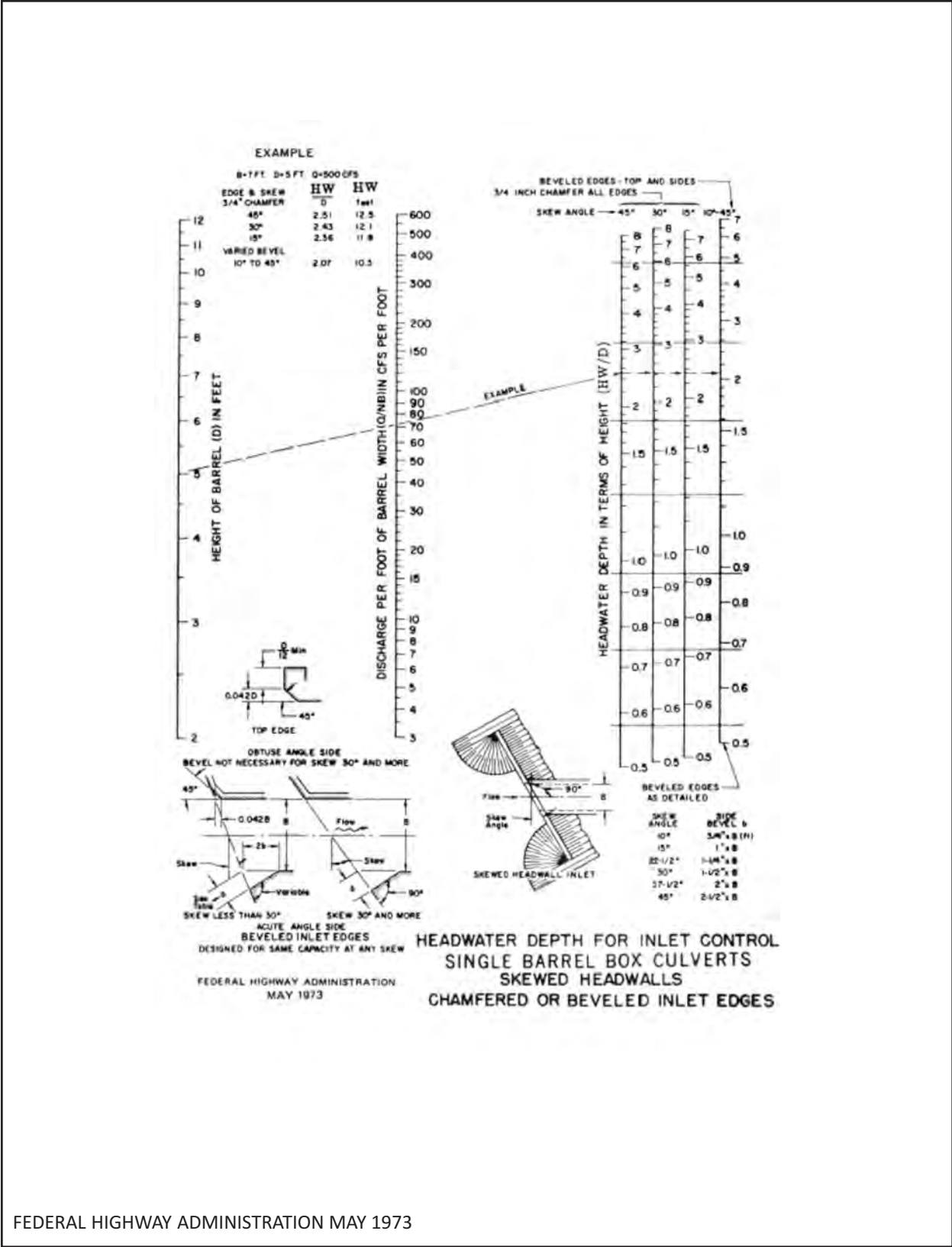

Figure 4-C-3 Headwater Depth For Inlet Control Single Barrel Box Culverts Skewed Headwalls Chamfered Or Beveled Inlet Edges

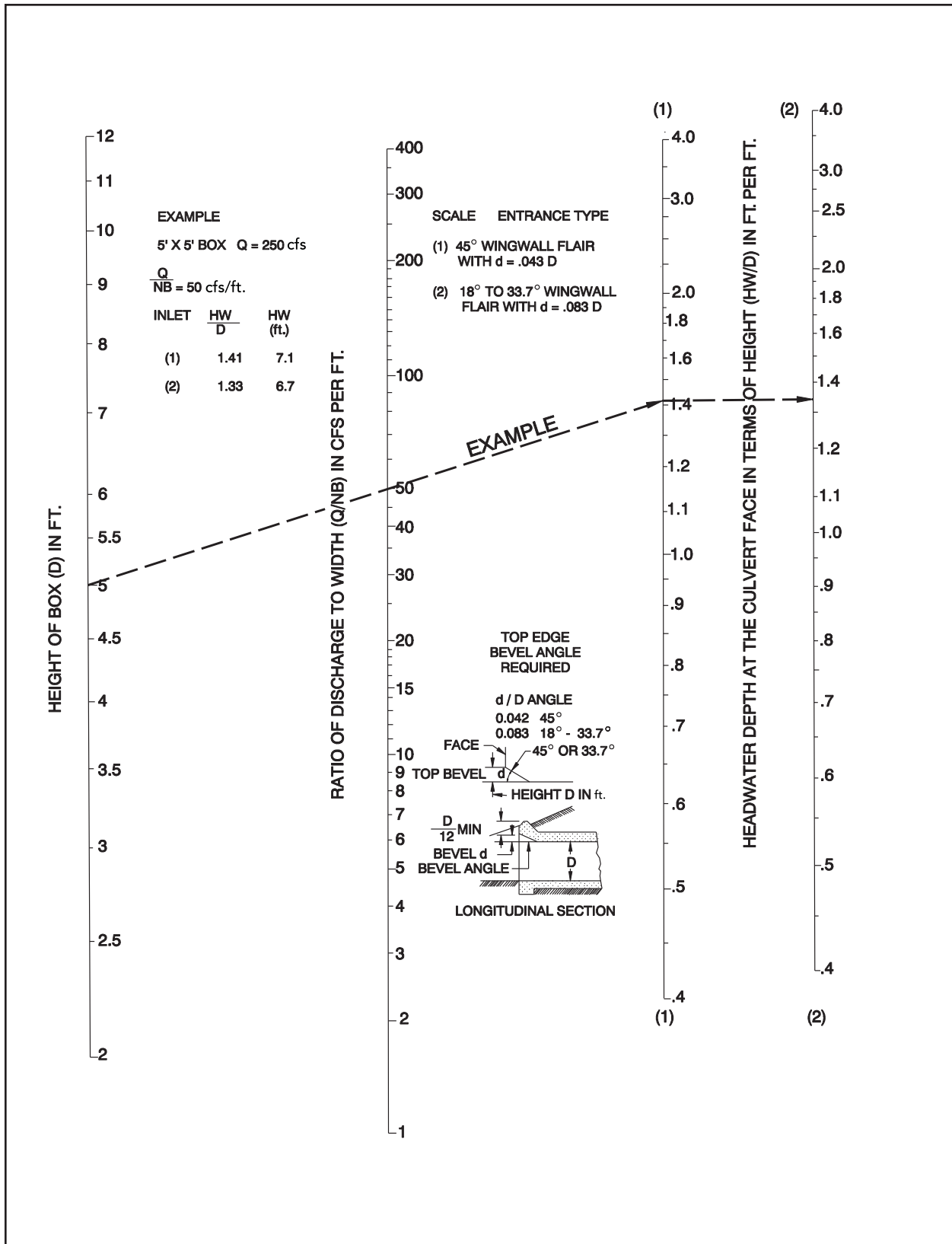

Figure 4-C-4 Headwater Depth For Inlet Control Rectangular Box Culverts Flared Wingwalls 18° to 33.7° & 45° With Beveled Edge At Top Of Inlet

Appendix 4-D  
HY8 Culvert Analysis —  
Microcomputer Program

(This page was intentionally left blank)

## Data Input For Culvert

As an initial size estimate, try a 24-in. circular culvert. For the culvert assume that a conventional inlet with headwall and square edges will be used. As each group of data is entered the user is allowed to edit any incorrect entries. The following will show the computer screens that the user will see.

After inputting the word CULVERT to start the program the following will appear on the computer screen.

```

                                CULVERT FILE MENU

                                TYPE LETTER OF DESIRED OPTION

                                <E>  EDIT OR USE A FILE
                                <C>  CREATE A FILE
                                <ESC> FOR MAIN PROGRAM MENU
  
```

Input a name for the file that will store all input data and press return to have the computer input the current date.

```

                                TYPE NEW CULVERT FILE NAME

                                FILE NAME ---> TEST

                                TYPE DATE OR <ENTER> FOR CURRENT DATE

                                DATE --->

                                <ESC> TO RETURN TO CULVERT FILE MENU
  
```

Input the design discharge (50-year peak discharge) and the maximum discharge (100-year peak discharge).

ENTER DESIGN AND MAXIMUM FLOW		
<1>	MINIMUM DISCHARGE (CFS)	0.0
<2>	DESIGN DISCHARGE (CFS)	60.0
<3>	MAXIMUM DISCHARGE (CFS)	110.0
<NUMBER>	TO EDIT DISCHARGE	
<ENTER>	TO CONTINUE	

Select<2> Culvert Invert Data

Input the culvert invert data which will be used to determine the length, slope, and elevations associated with this culvert installation.

CULVERT INVERT DATA		
NO.	ITEM	VALUE
<1>	INLET STATION (ft.)	100.00
<2>	INLET ELEVATION (ft.)	950.00
<3>	OUTLET STATION (ft.)	175.00
<4>	OUTLET ELEVATION (ft.)	947.00
<5>	ENTER NUMBER OF BARRELS	1

Select a culvert shape (for this example a circular culvert was selected).

SELECT A CULVERT SHAPE:	
<1>	CIRCULAR
<2>	BOX
<3>	ELLIPTICAL
<4>	PIPE ARCH
<5>	USER DEFINED (COORDINATES)
<6>	ARCH
<7>	LOW-PROFILE ARCH
<8>	HIGH PROFILE ARCH
<9>	METAL BOX

Specify the culvert diameter to be used for the first analysis.

```

CIRCULAR CULVERT
CULVERT DIAMETER (ft.) ---> 2*
<ESC> TO RETURN TO SHAPE MENU
  
```

Select a culvert material (for this example a concrete culvert was selected).

```

SELECT A CULVERT MATERIAL:
<1> CONCRETE
<2> CORRUGATED STEEL PLATE
<3> CORRUGATED ALUMINUM PLATE
  
```

Select an inlet type (for this example a conventional inlet was selected).

```

SELECT AN INLET TYPE:
<1> CONVENTIONAL
<2> SIDE-TAPERED, CIRCULAR
<3> SIDE TAPERED, RECTANGULAR
<4> SLOPE TAPERED
  
```

Select inlet conditions (for this example square edge with headwall was selected). Then specify if there is inlet depression (this example did not include any inlet depression).

```

SELECT AN INLET CONDITION:

CONVENTIONAL INLETS
<3> SQUARE EDGE WITH HEADWALL
<4> GROOVED END PROJECTION
<5> GROOVED END IN HEADWALL
<6> BEVELED EDGE (1:1)
<7> BEVELED EDGE (1.5:1)
  
```

Following is a summary table of the culvert input data.

ITEM	SELECTED CULVERT
<1> BARREL SHAPE:	CURCULAR
<2> BARREL SIZE:	2.00 ft. DIAMETER
<3> BARREL MATERIAL:	CONCRETE
<4> MANNING'S n:	.012
<5> INLET TYPE:	CONVENTIONAL
<6> INLET EDGE AND WALL:	SQUARE EDGE WITH HEADWALL
<7> INLET DEPRESSION:	NONE
<NUMBER> TO EDIT ITEM	
<ENTER> TO CONTINUE DATA LISTING	

At this point the user can edit any of the input data or press <ENTER> to continue.

### Data Input Downstream Channel

Following are the data related to the channel downstream from the culvert.

For the calculations of tailwater conditions, select the shape of the channel directly downstream from the outlet of the culvert (for this example a rectangular channel was selected).

TAILWATER RATING CURVE
PRESS NUMBER OF OPTION
<1> RECTANGULAR CHANNEL
<2> TRAPEZOIDAL CHANNEL
<3> TRIANGULAR CHANNEL
<4> IRREGULAR CHANNEL (MAX. 15 COORDINATES)
<5> ENTER RATING CURVE (11 POINTS)
<6> ENTER CONSTANT TAILWATER ELEVATION

For the downstream channel, input the bottom width, channel slope, Manning's n, and channel invert elevation.

ENTER TAILWATER CHANNEL DATA		
NO.	ITEM	VALUE
<1>	BOTTOM WIDTH (ft.)	5
<2>	SIDE SLOPE H:V __ : 1	
<3>	CHANNEL SLOPE (ft./ft.)	.04
<4>	MANNING'S N (.01-0.1)	.045
<5>	CHANNEL INVERT ELEVATION (ft.)	947
	CULVERT INVERT ELEVATION (ft.) (CULVERT NO. 1 OUTLET)	947.00
<NUMBER> TO EDIT ITEM <ENTER> TO CONTINUE DATA INPUT <ESC> FOR CHANNEL SHAPE MENU		

The table showing the Tailwater Rating Curve Data will not be calculated by the model. By pressing P you can obtain a plot of the Tailwater Data (Downstream Channel Rating Curve).

TAILWATER RATING CURVE				
NO.	FLOW (CFS)	T.W.E. (FT.)	VEL. (FPS)	SHEAR (PSF)
1	0.00	947.00	0.00	0.00
2	11.00	947.56	3.92	1.40
3	22.00	947.88	4.97	2.21
4	33.00	948.16	5.67	2.91
5	44.00	948.42	6.19	3.55
6	55.00	948.67	6.60	4.16
7	60.00	948.77	6.77	4.43
8	77.00	949.13	7.24	5.31
9	88.00	949.35	7.50	5.86
10	99.00	949.56	7.73	6.40
11	110.00	949.77	7.93	6.93
PRESS: <D> FOR DATA <P> TO PLOT RATING CURVE <ESC> FOR CHANNEL SHAPE MENU <ENTER> TO CONTINUE				

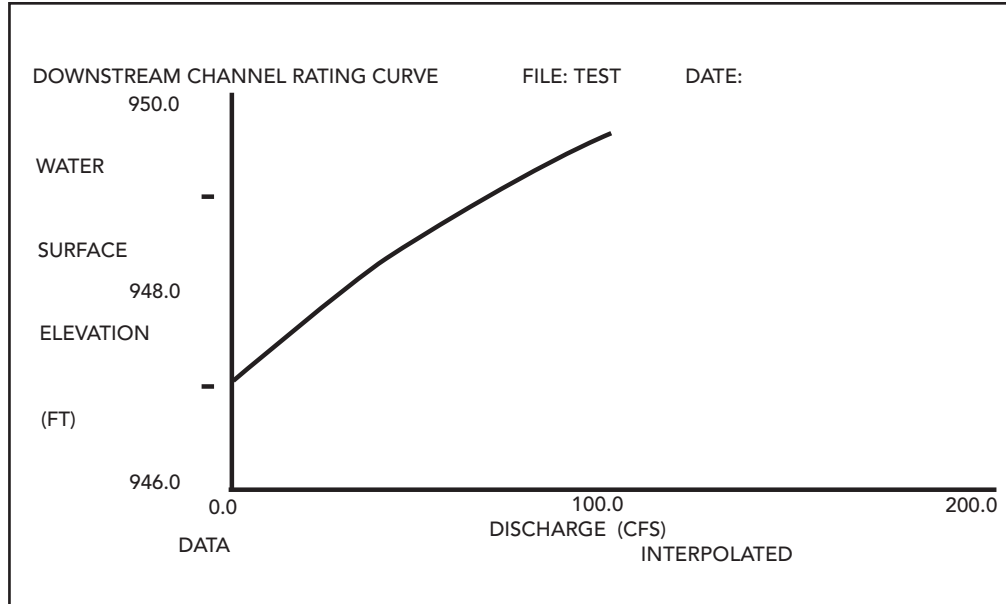

### Data Input Roadway

For overtopping analysis additional data will be needed about the roadway over the culvert installation.

Select a profile shape for the roadway above the culvert installation (for this example a constant roadway elevation was selected).

ROADWAY PROFILE SHAPE FOR OVERTOPPING ANALYSIS

SELECT PROFILE SHAPE:

<1> CONSTANT ROADWAY ELEVATION

<2> IRREGULAR (3 TO 15 COORDINATES)

Input the crest length and overtopping crest elevation.

ENTER PROFILE DATA		
NO.	ITEM	VALUE
<1>	CREST LENGTH (ft.)	50
<2>	OVERTOPPING CREST ELEVATION (ft.)	955*

Select a weir coefficient for the roadway section (for this example a paved roadway surface was selected).

WEIR COEFFICIENTS	
SELECT ROADWAY SURFACE OR A WEIR COEFFICIENT:	
<1>	PAVED ROADWAY SURFACE
<2>	GRAVEL ROADWAY SURFACE
<3>	INPUT COEFFICIENT OF DISCHARGE (2.5 - 3.095)
<ESC>	FOR LAST MENU

Select an overtopping crest elevation.

SELECTED OVERTOPPING CREST	
<1>	SHAPE: CONSTANT ROADWAY ELEVATION 955 ft.
<2>	CROSS-SECTION DATA
<3>	ROADWAY SURFACE: P
<4>	EMBANKMENT TOP WIDTH (ft.): 60*

Following is a summary table of the data input.

CULVERT ANALYSIS 3.1 CULVERT FILE: TEST		SUMMARY TABLE			DATE: CULVERT NO. 1			
C U L V N O. 1 2 3 4 5 6	<S> SITE DATA			<C> CULVERT SHAPE, MATERIAL, INLET				
	INLET ELEV. (ft.)	OUTLET ELEV. (ft.)	CULVERT LENGTH (ft.)	BARRELS SHAPE MATERIAL	SPAN (ft.)	RISE (ft.)	MANNING n	INLET TYPE
1	950.00	947.00	75	1 - RCP	2.00	2.00	.012	CONVENTIONAL
2								
3								
4								
5								
6								

PRESS TO REVIEW	PRESS TO
<C> CULVERT DATA	<E> EDIT CULVERT SIZE
<D> DISCHARGE DATA	<M> MINIMIZE CULVERT SPAN
<O> OVERTOPPING DATA	<A> ADD OR DELETE CULVERTS
<S> SITE DATA	
<T> TAILWATER RATING CURVE	
	<ENTER> TO CONTINUE

The user can now edit any data input either to correct errors or to try different analysis for different conditions or culvert designs.

## Analysis

Overtopping Analysis – If the user wants to take into account roadway overtopping, then this alternative should be selected. Otherwise select the no overtopping analysis option. The model will then perform the flow analysis and calculate how much flow will pass through the culvert and how much flow will overtop the roadway. The user can then plot the culvert rating curve and/or print a summary of the culvert data and analysis.

```

                                CULVERT PROGRAM OPTIONS

                                PRESS LETTER OF DESIRED OPTION

                                <O>  OVERTOPPING ANALYSIS
                                       INLET CONTROL  - HDS5 NOMOGRAPHS
                                       OUTLET CONTROL - FULL BARREL FLOW
                                       OVERTOPPING   - WIER EQUATION

                                <N>  NO OVERTOPPING ANALYSIS (CULVERT NUMBER 1)
                                       INLET CONTROL  - HDS5 NOMOGRAPHS
                                       OUTLET CONTROL - FULL BARREL FLOW

                                <B>  OUTLET CONTROL METHOD
                                <S>  SAVE MENU
                                <D>  DATA SUMMARY
                                <F>  FILE MENU      SAVE FILE BEFORE <F> OR <M>
                                <M>  MAIN MENU      OR FILE WILL BE LOST

                                1HELP  2      3      4      5END  6      7      8      9SHELL  10
-----
                                SUMMARY OF CULVERT FLOWS (CFS)      FILE: TEST      DATE:
-----
                                ELEV (FT.)  TOTAL  1      2      3      4      5      6  OVERTOP  ITER
                                950.00      0      0      0      0      0      0      0      0      0
                                951.77      11     11     0      0      0      0      0      0      1
                                953.77      22     22     0      0      0      0      0      0      1
                                955.07      33     31     0      0      0      0      0      3      2
                                955.20      44     31     0      0      0      0      0      13     2
                                955.30      55     32     0      0      0      0      0      24     2
                                955.33      60     32     0      0      0      0      0      29     2
                                955.45      77     32     0      0      0      0      0      46     2
                                955.52      88     32     0      0      0      0      0      56     2
                                955.58      99     33     0      0      0      0      0      67     2
                                955.64     110    33     0      0      0      0      0      78     2
-----
                                955.00      30     30     0      0      0      0      0      0  OVERTOPPING
-----

                                PRESS: <1> TO PLOT TOTAL RATING CURVE
                                       <2> TO DETERMINE SPECIFIC INFORMATION ABOUT EACH CULVERT
                                       <3> TO SEE MULTIPLE CULVERT COMPUTATIONAL ERROR TABLE
                                       <4> TO PRINT CULVERT SUMMARY
                                       <ENTER> TO RETURN FOR NEW RUN OR EXIT

```

### Changing Data

After reviewing the data for the first analysis, it is obvious that too much flow is overtopping the road with very little flow passing through the culvert. Thus another analysis will be performed with the overtopping elevation increased to 955.

Before leaving the first analysis be sure to save the file (for this example the file was saved under the name TEST).

```
SAVE MENU
TYPE LETTER OF DESIRED OPTION
<R> TO RENAME FILE
<F> FOR FILE LISTING
<S> TO SAVE FILE
<ENTER> TO RETURN
```

Return to the Culvert File Menu and select <E> to edit an existing file.

```
CULVERT FILE MENU
TYPE LETTER OF DESIRED OPTION
<E> EDIT OR USE A FILE
<C> CREATE A FILE
<ESC> FOR MAIN PROGRAM MENU
```

Select C for culvert data and sheet #2 to change the culvert size from 2 to 3 ft.

```
CIRCULAR CULVERT
CULVERT DIAMETER (ft.) ----> 3*
```

Proceed with the overtopping and analysis and obtain the following results.

SUMMARY OF CULVERT FLOWS (CFS)										FILE: TEST	DATE:
ELEV. (FT.)	TOTAL	1	2	3	4	5	6	OVERTOP	ITER		
950.00	0	0	0	0	0	0	0	0	0	0	
951.39	11	11	0	0	0	0	0	0	0	1	
952.17	22	22	0	0	0	0	0	0	0	1	
952.82	33	33	0	0	0	0	0	0	0	1	
953.51	44	44	0	0	0	0	0	0	0	1	
954.35	55	55	0	0	0	0	0	0	0	1	
954.79	60	60	0	0	0	0	0	0	0	1	
955.21	77	64	0	0	0	0	0	14	3		
955.30	88	65	0	0	0	0	0	24	3		
955.38	99	66	0	0	0	0	0	35	3		
955.45	110	67	0	0	0	0	0	45	3		
955.00	62	62	0	0	0	0	0	0	0	(OVERTOPPING)	

PRESS: <1> TO PLOT TOTAL RATING CURVE  
 <2> TO DETERMINE SPECIFIC INFORMATION ABOUT EACH CULVERT  
 <3> TO SEE MULTIPLE CULVERT COMPUTATIONAL ERROR TABLE  
 <4> TO PRINT CULVERT SUMMARY  
 <ENTER> TO RETURN FOR NEW RUN OR EXIT

This table shows that the design flow of 60 cfs will pass through the culvert while the additional flow from the 100-year storm will overtop the roadway.

### Additional Analysis

Numerous other design selections could be analyzed including different culvert materials, improved inlets, different size culverts, etc. In addition, the model has another feature that is very useful. When the Summary Table appears on the screen there is an option <M> which will calculate the minimum size culvert need to accommodate the design flow given the other data provided in the analysis. Using this option, the following table shows that a 2.5 ft. (30 in.) culvert could be used if the allowable headwater elevation could be increased to 957.21.

CULVERT ANALYSIS 3.1				SUMMARY TABLE				DATE:
CULVERT FILE: TEST								CULVERT NO. 1
C U L V E R T A N A L Y S I S 3 . 1	<S> SITE DATA			<C> CULVERT SHAPE, MATERIAL, INLET				
	INLET ELEV. (ft.)	OUTLET ELEV. (ft.)	CULVERT LENGTH (ft.)	BARRELS SHAPE MATERIAL	SPAN (ft.)	RISE (ft.)	MANNING n	INLET TYPE
	1 950.00	947.00	75	1 - RCP	2.50	2.50	.012	CONVENTIONAL
	2							
	3							
	4							
	5							
6								
HEADWATER ELEVATION			FLOW VELOCITY			FLOW VELOCITY		
ENTER ALLOWABLE = 958.00			CULVERT = 19.46			CULVERT = 1.50		
CONTROLLING = 957.56			CHANNEL = 6.77			CHANNEL = 1.77		
INLET CONTROL = 957.56			DISCHARGE = 60.00			NORMAL = 1.50		
OUTLET CONTROL = 954.34			SLOPE = 0.0400			CRITICAL = 2.50		
MAXIMUM HEADWATER			<ENTER> TO CHANGE HEADWATER			<ANY KEY> TO RETURN		

(This page was intentionally left blank)

## Appendix 4-E

### References

(This page was intentionally left blank)

American Association of State Highway and Transportation Officials. Highway Drainage Guidelines. 1982.

City of Lincoln, Nebraska Drainage Criteria Manual. February 2000, Revision – May 2004.

Federal Highway Administration. Hydraulics of Bridge Waterways. Hydraulic Design Series No. 1. 1978.

Federal Highway Administration. Hydraulic Design of Highway Culverts. Hydraulic Design Series No. 5. 1985.

Federal Highway Administration. Debris-Control Structures. Hydraulic Engineering Circular No. 9. 1971.

Federal Highway Administration. HY8 Culvert Analysis Microcomputer Program Applications Guide. Hydraulic Microcomputer Program HY8. 1987.

HYDRAIN Culvert Computer Program (HY8). Available from McTrans Software, University of Florida, 512 Weil Hall, Gainesville, Florida 32611.

U. S. Department of Interior. 1983. Design of Small Canal Structures.